

W65C265S
INFORMATION, SPECIFICATION AND DATA SHEET

P67/TXD3
 P66/RXD3/NE66
 P65/TXD2
 P64/RXD2/NE64
 P63/TXD1
 P62/RXD1/PWM
 P61/TXD0/TOUT
 P60/RXD0/TIN/PE60
 P57/PID7/NE57
 P56/PID6/PE56
 VSS
 VDD
 P55/PID5
 P54/PID4
 P53/PID3
 P52/PID2
 P51/PID1
 P50/PID0
 P47/PIRS2
 P46/PIRS1
 P45/PIRS0

	11	10	9	8	7	6	5	4	3	2	1	84	83	82	81	80	79	78	77	76	75		
RESB	12																					74	P44/PICSB/PICS
WEB	13																					73	P43/PIWEB
RUN/SYNC	14																					72	P42/PIB
FCLKOB	15																					71	P41/IRQB
FCLK	16																					70	P40/NMIB/ABORTB
BE/RDY	17																					69	TG1
CLK	18																					68	TG0
CLKOB	19																					67	P27/D7
PHI2	20																					66	P26/D6
BA/DODB	21																					65	P25/D5
VSS	22																					64	VSS
VDD	23																					63	VDD
P00/A0	24																					62	P24/D4
P01/A1	25																					61	P23/D3
P02/A2	26																					60	P22/D2
P03/A3	27																					59	P21/D1
P04/A4	28																					58	P20/D0
P05/A5	29																					57	P77/CS7B
P06/A6	30																					56	P76/CS6B
P07/A7	31																					55	P75/CS5B
P10/A8	32																					54	P74/CS4B
		33	34	35	36	37	38	39	40	41	42	43	44	45	46	47	48	49	50	51	52	53	

W65C265S
 84 LEAD
 CHIP CARRIER

P11/A9
 P12/A10
 P13/A11
 P14/A12
 P15/A13
 P16/A14
 P17/A15
 P30/A16
 P31/A17
 P32/A18
 VSS
 VDD
 P33/A19
 P34/A20
 P35/A21
 P36/A22
 P37/A23
 P70/CS0B
 P71/CS1B
 P72/CS2B
 P73/CS3B

INFORMATION, SPECIFICATION AND DATA SHEET

1. GENERAL INFORMATION
 2. SPECIFICATIONS
 3. MATERIALS
 4. CONSTRUCTION
 5. MAINTENANCE
 6. TESTING
 7. FINISHES
 8. ACCESSORIES
 9. NOTES

PROJECT NO. 100-100-100
 DRAWING NO. 100-100-100
 DATE 10/10/10

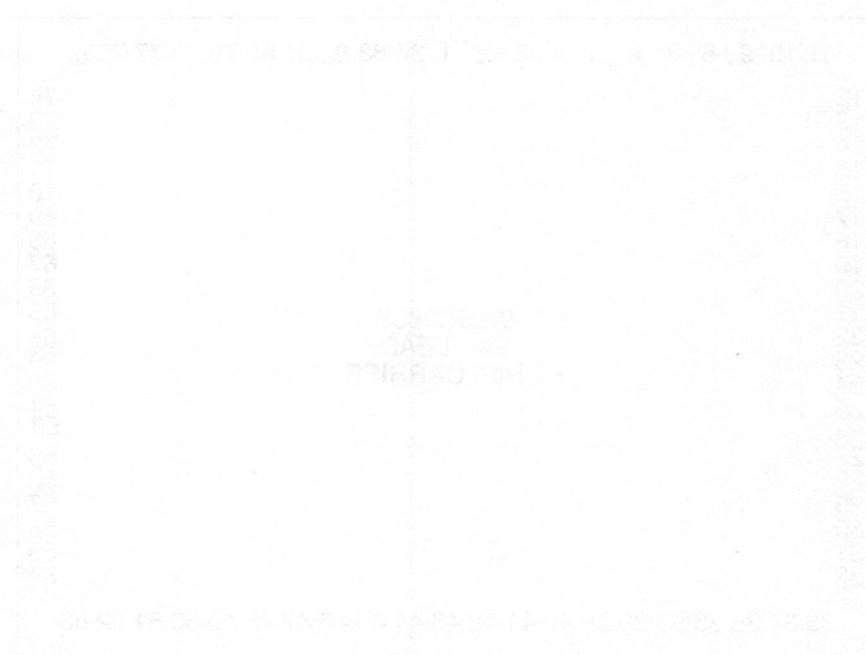

CONTRACT NO. 100-100-100
 SHEET NO. 100-100-100

1. GENERAL INFORMATION
 2. SPECIFICATIONS
 3. MATERIALS
 4. CONSTRUCTION
 5. MAINTENANCE
 6. TESTING
 7. FINISHES
 8. ACCESSORIES
 9. NOTES

WDC reserves the right to make changes at any time without notice in order to improve design and supply the best possible product. Information contained herein is provided gratuitously and without liability, to any user. Reasonable efforts have been made to verify the accuracy of the information but no guarantee whatsoever is given as to the accuracy or as to its applicability to particular uses. In every instance, it must be the responsibility of the user to determine the suitability of the products for each application. WDC products are not authorized for use as critical components in life support devices or systems. Nothing contained herein shall be construed as a recommendation to use any product in violation of existing patents or other rights of third parties. The sale of any WDC product is subject to all WDC Terms and Conditions of Sales and Sales Policies, copies of which are available upon request.

Copyright (C) 1981-1990 by The Western Design Center, Inc. All rights reserved, including the right of reproduction in whole or in part in any form.

WDC reserves the right to make changes in any time without notice in order to improve design and supply the best possible product. Information contained herein is for informational purposes only and does not constitute an offer or any other financial product. The accuracy of the information contained herein is given as to the accuracy of the information as of the date of the particular use. In every instance, it must be the responsibility of the user to determine the reliability of the numbers for each application. WDC products are not warranted to be used as capital equipment in the design or development of systems. Nothing contained herein shall be construed as a recommendation to use any product or information of any other party or other third party. The use of any WDC product is subject to the WDC Terms and Conditions of Sale and other policies, terms, conditions, and notices which are available on request.

Copyright © 1981 by The Western Design Center, Inc. All rights reserved. Nothing herein shall be construed as a recommendation to use any product or information of any other party or other third party.

TABLE OF CONTENTS

INTRODUCTION		1
SECTION 1 W65C265S FUNCTION DESCRIPTION		2
1.1	The W65C816S Static 8-and 16-bit Microprocessor Core	2
1.2	8K x 8 ROM	2
1.3	576 x 8 RAM	2
1.4	Bus Control Register	2
	Table 1-1 BCR7 and BE/RDY Control	3
	Figure 1-1 BE/RDY Timing Relative to RESB Input	3
	Figure 1-2 Bus Control Register	4
1.5	The Timers	5
	Table 1-2 The Timer Functions	5
	Figure 1-3 Timer Control Register	6
	Figure 1-4 Timer Enable Register	6
1.6	Interrupt Flag Registers	7
1.7	Interrupt Enable Registers	7
	Figure 1-5 Timer Interrupt Enable Register and Timer Interrupt Flag Register	8
	Figure 1-6 Edge Interrupt Enable Register and Edge Interrupt Flag Register	8
	Figure 1-7 UART Interrupt Enable Register and UART Interrupt Flag Register	9
1.8	Asynchronous I/O Data Rate Generation	10
	Table 1-3 Timer 3 and 4 Values for Baud Rate Selection	10
1.9	Universal Asynchronous Receiver/Transmitters	11
	Figure 1-8 Asynchronous Transmitter Mode with Parity	11
	Figure 1-9 Asynchronous Data Timing for 7-bit Data without Parity	12
	Figure 1-10 ACSR _x Bit Assignments	13
1.10	The Parallel Interface Bus	14
	Figure 1-11 The PIB Registers	14
	Figure 1-12 Parallel Interface Bus Enable and Flag Registers	15
1.11	Twin Tone Generators	16
	Figure 1-13 Tone Generator Block Diagram	16
	Table 1-4 Communications Frequencies Generated by Tone Generator Timers 5, 6	17
1.12	Processor Defined Cache Control	18
	Figure 1-14 System Speed Control Register	18
	Figure 1-15 System Speed Change Timing Diagram	19
1.13	Programming Model and Memory Map	20
	Figure 1-16 W65C816S Programming Model and Memory Map	20
	Table 1-5 System Memory Map	21
	Table 1-6A I/O Register Memory Map	22
	Table 1-6B Control and Status Register Memory Map	23
	Table 1-6C Timer Register Memory Map	24
	Table 1-6D Communication Register Memory Map	25
	Table 1-7A Emulation Mode Vector Table	26
	Table 1-7B Native Mode Vector Table	27
	Table 1-8A W65C265S 84 Lead Pin Map	28

TABLE OF CONTENTS

ABBREVIATIONS

SECTION 1 - FUNCTIONAL DESCRIPTION

1.1	The WOODS 8000 and Local Management Console	1-1
1.2	8000 Series	1-2
1.3	8000 Series	1-3
1.4	Local Register	1-4
1.5	Local Register	1-5
1.6	Local Register	1-6
1.7	Local Register	1-7
1.8	Local Register	1-8
1.9	Local Register	1-9
1.10	Local Register	1-10
1.11	Local Register	1-11
1.12	Local Register	1-12
1.13	Local Register	1-13
1.14	Local Register	1-14
1.15	Local Register	1-15
1.16	Local Register	1-16
1.17	Local Register	1-17
1.18	Local Register	1-18
1.19	Local Register	1-19
1.20	Local Register	1-20
1.21	Local Register	1-21
1.22	Local Register	1-22
1.23	Local Register	1-23
1.24	Local Register	1-24
1.25	Local Register	1-25
1.26	Local Register	1-26
1.27	Local Register	1-27
1.28	Local Register	1-28
1.29	Local Register	1-29
1.30	Local Register	1-30
1.31	Local Register	1-31
1.32	Local Register	1-32
1.33	Local Register	1-33
1.34	Local Register	1-34
1.35	Local Register	1-35
1.36	Local Register	1-36
1.37	Local Register	1-37
1.38	Local Register	1-38
1.39	Local Register	1-39
1.40	Local Register	1-40
1.41	Local Register	1-41
1.42	Local Register	1-42
1.43	Local Register	1-43
1.44	Local Register	1-44
1.45	Local Register	1-45
1.46	Local Register	1-46
1.47	Local Register	1-47
1.48	Local Register	1-48
1.49	Local Register	1-49
1.50	Local Register	1-50
1.51	Local Register	1-51
1.52	Local Register	1-52
1.53	Local Register	1-53
1.54	Local Register	1-54
1.55	Local Register	1-55
1.56	Local Register	1-56
1.57	Local Register	1-57
1.58	Local Register	1-58
1.59	Local Register	1-59
1.60	Local Register	1-60
1.61	Local Register	1-61
1.62	Local Register	1-62
1.63	Local Register	1-63
1.64	Local Register	1-64
1.65	Local Register	1-65
1.66	Local Register	1-66
1.67	Local Register	1-67
1.68	Local Register	1-68
1.69	Local Register	1-69
1.70	Local Register	1-70
1.71	Local Register	1-71
1.72	Local Register	1-72
1.73	Local Register	1-73
1.74	Local Register	1-74
1.75	Local Register	1-75
1.76	Local Register	1-76
1.77	Local Register	1-77
1.78	Local Register	1-78
1.79	Local Register	1-79
1.80	Local Register	1-80
1.81	Local Register	1-81
1.82	Local Register	1-82
1.83	Local Register	1-83
1.84	Local Register	1-84
1.85	Local Register	1-85
1.86	Local Register	1-86
1.87	Local Register	1-87
1.88	Local Register	1-88
1.89	Local Register	1-89
1.90	Local Register	1-90
1.91	Local Register	1-91
1.92	Local Register	1-92
1.93	Local Register	1-93
1.94	Local Register	1-94
1.95	Local Register	1-95
1.96	Local Register	1-96
1.97	Local Register	1-97
1.98	Local Register	1-98
1.99	Local Register	1-99
1.100	Local Register	1-100

SECTION 2	PIN FUNCTION DESCRIPTION	31
	Figure 2-1 W65C265S Interface Diagram	31
	Figure 2-2 W65C265S 84 Lead Chip Carrier Pinout Designation	32
2.1	Write Enable	33
2.2	RUN and SYNC	33
2.3	Phase 2 Clock Output	33
2.4	Clock Inputs	33
2.5	Bus Enable and RDY Input	34
	Figure 2-5 BE/RDY Timing Relative to PHI2	34
2.6	Reset Input/Output	35
2.7	Positive Power Supply	35
2.8	Internal Logic Ground	35
2.9	I/O Port Pins	35
2.10	Address Bus	35
2.11	Data Bus	36
2.12	Positive Edge Interrupt inputs	36
2.13	Negative Edge Interrupt inputs	36
2.14	Chip Select outputs	36
2.15	Level Sensitive Interrupt Request input	36
2.16	Non-Maskable Edge and ABORT Interrupt Input	36
2.17	Asynchronous Receive Inputs/Transmitter Outputs	37
2.18	Timer 4 Input and Output	37
2.19	Bus Available/Disable Output Data	37
2.20	Tone Generator Outputs	37
2.21	Parallel Interface Bus	37
2.22	Pulse Width Measurement Input	38
SECTION 3	TIMING, AC AND DC CHARACTERISTICS	39
3.1	Absolute Maximum Ratings	39
	Table 3-1 Absolute Maximum Ratings	39
3.2	DC Characteristics	40
	Table 3-2 DC Characteristics	40
3.3	AC Characteristics	41
	Table 3-3 AC Characteristics	41
3.4	AC Parameters	42
	Table 3-4 AC Parameters	42
3.5	AC Timing Diagram Notes	43
3.6	AC Timing Diagrams	44
	Figure 3-1 AC Timing Diagram #1	44
	Figure 3-2 AC Timing Diagram #2	45
	Figure 3-3 AC Timing Diagram #3	46
	Figure 3-4 AC Timing Diagram #4	47
SECTION 4	ORDERING INFORMATION	48

SECTION 2. POLLUTION CONTROL

11	2.1	Water Quality Standards
12	2.2	Water Quality Criteria
13	2.3	Water Quality Monitoring
14	2.4	Water Quality Assessment
15	2.5	Water Quality Improvement
16	2.6	Water Quality Protection
17	2.7	Water Quality Enforcement
18	2.8	Water Quality Research
19	2.9	Water Quality Education
20	2.10	Water Quality Planning
21	2.11	Water Quality Management
22	2.12	Water Quality Conservation
23	2.13	Water Quality Restoration
24	2.14	Water Quality Preservation
25	2.15	Water Quality Enhancement
26	2.16	Water Quality Maintenance
27	2.17	Water Quality Protection
28	2.18	Water Quality Conservation
29	2.19	Water Quality Restoration
30	2.20	Water Quality Preservation
31	2.21	Water Quality Enhancement
32	2.22	Water Quality Maintenance

SECTION 3. WATER QUALITY STANDARDS

33	3.1	Water Quality Standards
34	3.2	Water Quality Criteria
35	3.3	Water Quality Monitoring
36	3.4	Water Quality Assessment
37	3.5	Water Quality Improvement
38	3.6	Water Quality Protection
39	3.7	Water Quality Enforcement
40	3.8	Water Quality Research
41	3.9	Water Quality Education
42	3.10	Water Quality Planning
43	3.11	Water Quality Management
44	3.12	Water Quality Conservation
45	3.13	Water Quality Restoration
46	3.14	Water Quality Preservation
47	3.15	Water Quality Enhancement
48	3.16	Water Quality Maintenance
49	3.17	Water Quality Protection
50	3.18	Water Quality Conservation
51	3.19	Water Quality Restoration
52	3.20	Water Quality Preservation
53	3.21	Water Quality Enhancement
54	3.22	Water Quality Maintenance

SECTION 4. WATER QUALITY MONITORING

55	4.1	Water Quality Monitoring
56	4.2	Water Quality Criteria
57	4.3	Water Quality Monitoring
58	4.4	Water Quality Assessment
59	4.5	Water Quality Improvement
60	4.6	Water Quality Protection
61	4.7	Water Quality Enforcement
62	4.8	Water Quality Research
63	4.9	Water Quality Education
64	4.10	Water Quality Planning
65	4.11	Water Quality Management
66	4.12	Water Quality Conservation
67	4.13	Water Quality Restoration
68	4.14	Water Quality Preservation
69	4.15	Water Quality Enhancement
70	4.16	Water Quality Maintenance
71	4.17	Water Quality Protection
72	4.18	Water Quality Conservation
73	4.19	Water Quality Restoration
74	4.20	Water Quality Preservation
75	4.21	Water Quality Enhancement
76	4.22	Water Quality Maintenance

INTRODUCTION

The WDC W65C265S microcomputer is a complete fully static 16-bit computer fabricated on a single chip using a Hi-Rel low power CMOS process. The W65C265S complements an established and growing line of W65C products and has a wide range of microcomputer applications. The W65C265S has been developed for Hi-Rel applications and where minimum power is required.

The W65C265S consists of a W65C816S (Static) Central Processing Unit (CPU), 8K bytes of Read Only Memory (ROM), 576 bytes of Random Access Memory (RAM), Processor defined cache under software control, eight 16-bit timers with maskable interrupts, high performance interrupt driven Parallel Interface Bus (PIB), four Universal Asynchronous Receivers and Transmitters (UART) with baud rate timers, Monitor "Watch Dog" Timer with "restart" interrupt, twenty-nine priority encoded interrupts, Built-in Emulation features, Time of Day (ToD) clock features, Twin Tone Generators (TGx), Bus Control Register (BCR) for external memory bus control, interface circuitry for peripheral devices, ABORT input for low cost virtual memory interface, and many low power features.

The innovative architecture and the demonstrated high performance of the W65C265S CPU, as well as instruction simplicity, result in system cost-effectiveness and a wide range of computational power. These features make the W65C265S a leading candidate for 16-bit microcomputer applications especially where task oriented processing is desired.

This product description assumes that the reader is familiar with the W65C816 CPU hardware and programming capabilities. Refer to the W65C816 Data Sheet for additional information.

KEY FEATURES OF THE W65C265S

- Hi-Rel low power CMOS process
- Operating TA = -55°C to +125°C
- Single 2.0V to 5.5V power supply
- Static to 4MHz clock operation
- W65C816S compatible CPU
 - 8- and 16-bit parallel processing
 - Variable length stack
 - True indexing capability
 - Twenty-four address modes
 - Decimal or binary arithmetic
 - Pipeline architecture
 - Fully static CPU
 - W65C832S 32-bit CPU compatible
- Single chip microcomputer
 - 2 Twin Tone Generators
 - 64 CMOS compatible I/O lines
 - 8K x 8 ROM on-chip
 - 576 x 8 RAM on-chip
 - WAIt for interrupt
 - SToP the clock
 - Fast oscillator start and stop feature
- 16Mbyte linear address space
- Twenty-nine priority encoded interrupts
 - BRK software interrupt
 - RESET "RESTART" interrupt
 - NMIB Non-Maskable interrupt
 - ABORT interrupt
 - COP software interrupt
 - IRQB level interrupt
 - 8 timer edge interrupts
 - 6 edge interrupts
 - PIB interrupt
 - 4 UART Receiver interrupts
 - 4 UART Transmitter interrupts
- Four UARTS's
- Time of Day (ToD) clock features
- 8 x 16 bit timer/counters
- Bus Control Register
 - Many bus operating features and modes
 - 8 Programmable chip select outputs
- Low cost 84 lead PLCC and 80 lead QIP packages
- Hi-Rel 84 lead ceramic packages
- Macro assembler available
- C, Basic and Pascal compilers available

INTRODUCTION

The W35002 is a high-speed, low-power, 8-bit microprocessor. It is designed for use in a wide variety of applications, including data processing, control systems, and communications. The W35002 is a single-chip device that integrates the CPU, memory, and peripheral functions. It is available in both 16-pin DIP and 28-pin DIP packages.

The W35002 consists of a 4-bit ALU, a 4-bit register file, and a 4-bit instruction decoder. It also includes a 4-bit bus interface, a 4-bit stack pointer, and a 4-bit program counter. The W35002 is designed to operate at a clock rate of 10 MHz. It is a high-speed, low-power device that is suitable for use in a wide variety of applications.

The W35002 is a high-speed, low-power, 8-bit microprocessor. It is designed for use in a wide variety of applications, including data processing, control systems, and communications. The W35002 is a single-chip device that integrates the CPU, memory, and peripheral functions. It is available in both 16-pin DIP and 28-pin DIP packages.

The W35002 is a high-speed, low-power, 8-bit microprocessor. It is designed for use in a wide variety of applications, including data processing, control systems, and communications. The W35002 is a single-chip device that integrates the CPU, memory, and peripheral functions. It is available in both 16-pin DIP and 28-pin DIP packages.

KEY FEATURES OF THE W35002

- 8-bit ALU
- 4-bit register file
- 4-bit instruction decoder
- 4-bit bus interface
- 4-bit stack pointer
- 4-bit program counter
- 10 MHz clock rate
- Single-chip device
- Available in 16-pin and 28-pin DIP packages
- High-speed, low-power
- Suitable for data processing, control systems, and communications

SECTION 1

W65C265S FUNCTION DESCRIPTION

1.1 The W65C816S Static 8-and 16-bit Microprocessor Core

The W65C816S 16-bit microprocessor is the fully static (may be stopped when PHI2 is high or low) version of the popular W65C816 microprocessor used in the Apple IIgs personal computer system. The W65C816S is compatible with the NMOS 6502 and CMOS 65C02 used in many control applications and personal computers.

The small die size and low power consumption of the W65C816S offer an excellent choice as a cost effective 16-bit core microprocessor in one-chip microcomputers.

The W65C816S instruction set is compatible with the W65C02 and W65C02S, 8-bit microprocessors, W65C802 and W65C816, 16-bit microprocessors.

1.2 8K x 8 ROM (\$E000-\$FFFF)

The W65C265S 8K x 8 bit Read Only Memory (ROM) usually contains the user's program instructions, interrupt vectors, and other fixed constants. These are mask-programmed into the ROM during fabrication of the W65C265S device.

1.3 576 x 8 RAM (\$0000-\$01FF,\$DF80-\$DFBF)

The 576 x 8 bit Random Access Memory (RAM) contains the user program stack and is used for scratch pad memory during system operation. This RAM is completely static in operation and requires no clock or dynamic refresh. The data contained in RAM is read out nondestructively with the same polarity as the input data.

1.4 Bus Control Register (BCR)

- 1.4.1 The Bus Control Register (BCR) controls the various modes of I/O and external memory interface.
- 1.4.2 During power-up the value of BE/RDY defines the initial values of BCR0, BCR3 and BCR7, three bits in the BCR that set up the W65C265S for In-Circuit-Emulation (ICE) or test modes.
- 1.4.3 When BE/RDY goes high after RESB goes high the BCR sets up the W65C265S for emulation. Port 0 and 1 are the address outputs, Port 2 is the data I/O bus and RUN/SYNC is the multiplexed RUN/SYNC function. (see RUN/SYNC pin function description).
- 1.4.4 When BE/RDY goes high before RESB goes high, all bits in the BCR are "0".
- 1.4.5 After RESB goes high BE/RDY no longer effects the BCR register, and BCR may be written under software control to reconfigure the W65C265S as desired.

1.4.6 Table 1-1 indicates how BCR7 and BE/RDY define the W65C265S configuration.

Table 1-1 BCR7 and BE/RDY Control

BCR7	BE/RDY	W65C265S configuration
0	0	Internal ROM External Processor (DMA test mode)
0	1	Internal ROM Internal Processor
1	0	External ROM External Processor (DMA test mode)
1	1	External ROM Internal Processor

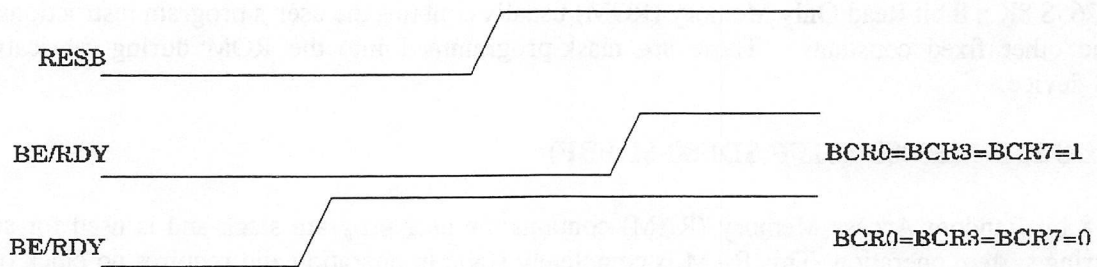

Figure 1-1 BE/RDY Timing Relative to RESB Input

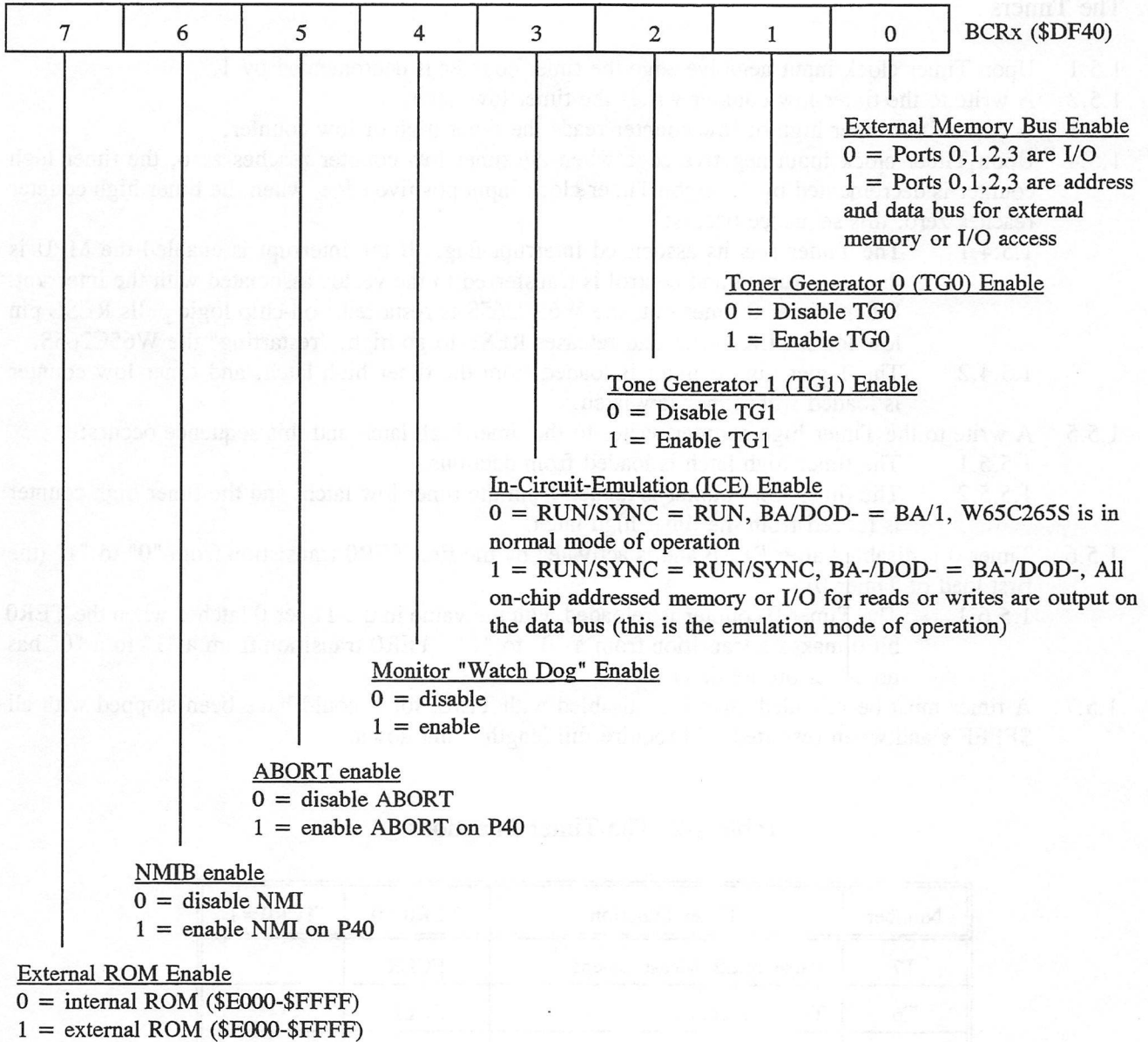

Figure 1-2 Bus Control Register (BCR)

1.5 The Timers

- 1.5.1 Upon Timer clock input negative edge the timer counter is decremented by 1.
- 1.5.2 A write to the timer low counter writes the timer low latch.
- 1.5.3 A read of the timer high or low counter reads the timer high or low counter.
- 1.5.4 Upon Timer clock input negative edge when the timer low counter reaches zero, the timer high counter is decremented by 1. Upon Timer clock input positive edge, when the timer high counter reaches zero, this sequence occurs:
 - 1.5.4.1 The Timer sets its associated interrupt flag. If the interrupt is enabled the MPU is then interrupted and control is transferred to the vector associated with the interrupt. When Timer 0 times out, the W65C265S is restarted: on-chip logic pulls RESB pin low for 2 CLK cycles and releases RESB to go high, "restarting" the W65C265S.
 - 1.5.4.2 The Timer high counter is loaded from the timer high latch, and timer low counter is loaded from timer low latch.
- 1.5.5 A write to the Timer high counter writes to the timer high latch and this sequence occurs:
 - 1.5.5.1 The timer high latch is loaded from data bus.
 - 1.5.5.2 The timer low counter is loaded from the timer low latch, and the timer high counter is loaded from the timer high latch.
- 1.5.6 Timer 0 is disabled after RESB and is activated by the first TER0 transition from "0" to "1" (the first load of Timer 0).
 - 1.5.6.1 The Timer 0 counter is reloaded with the value in the Timer 0 latches when the TER0 bit 0 makes a transition from a "0" to "1". TER0 transition from a "1" to a "0" has no effect on the timer.
- 1.5.7 A timer must be reloaded after it is disabled with TERx for it could have been stopped with all \$FFFF's and when restarted will require full length count down.

Table 1-2 The Timer Functions

Number	Timer Function	TCR0=0	TCR0=1
T7	Pulse Width Measurement	FCLK	-
T6	Tone Generator	FCLK	-
T5	Tone Generator	FCLK	-
T4	UART Baud Rate or Pulse, Input/Output	FCLK	P60
T3	UART Baud Rate	FCLK	-
T2	Prescaled Interrupt	FCLK/16	-
T1	Time of Day	CLK	-
T0	Monitor Watch Dog	CLK	-

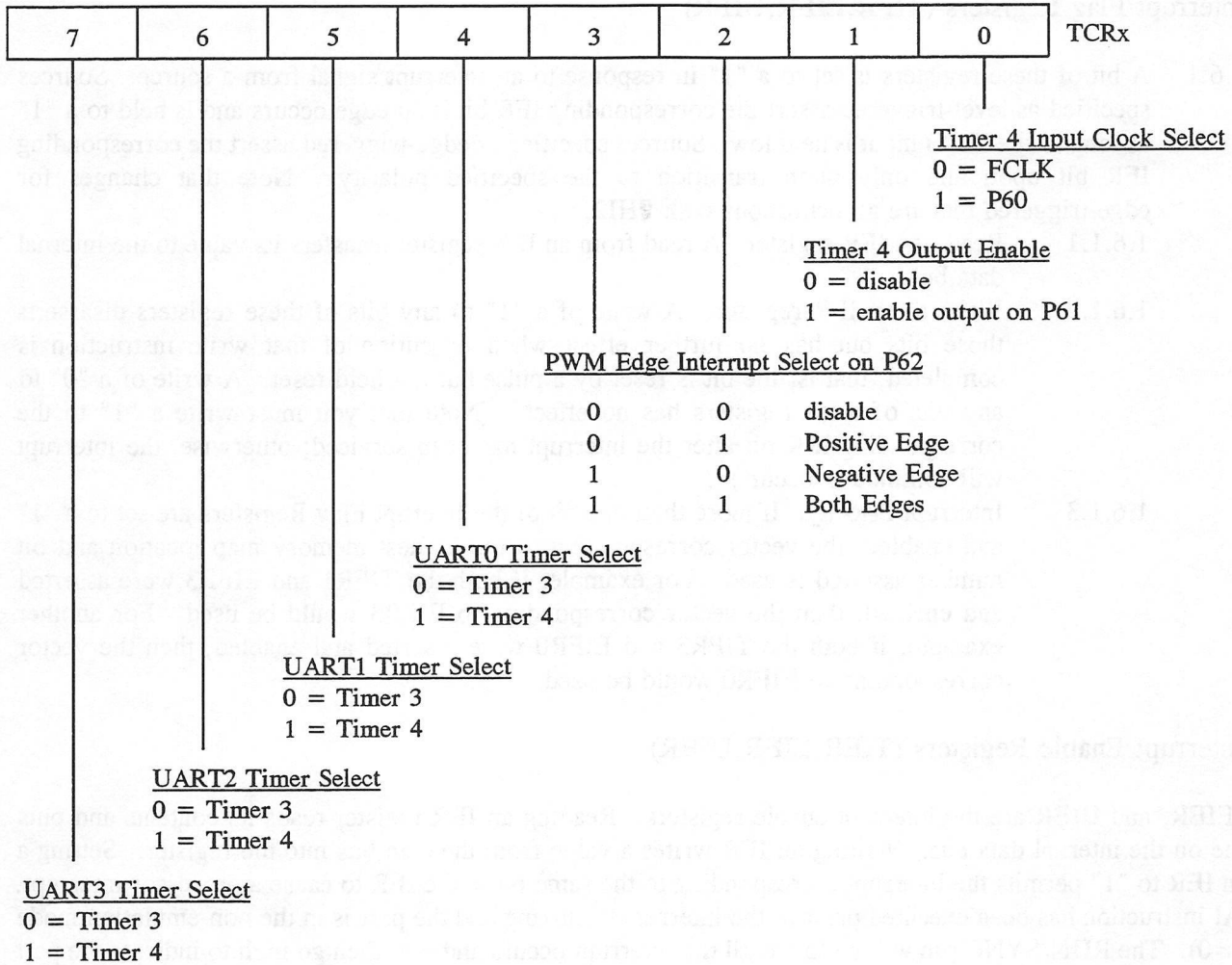

Figure 1-3 Timer Control Register (TCR)

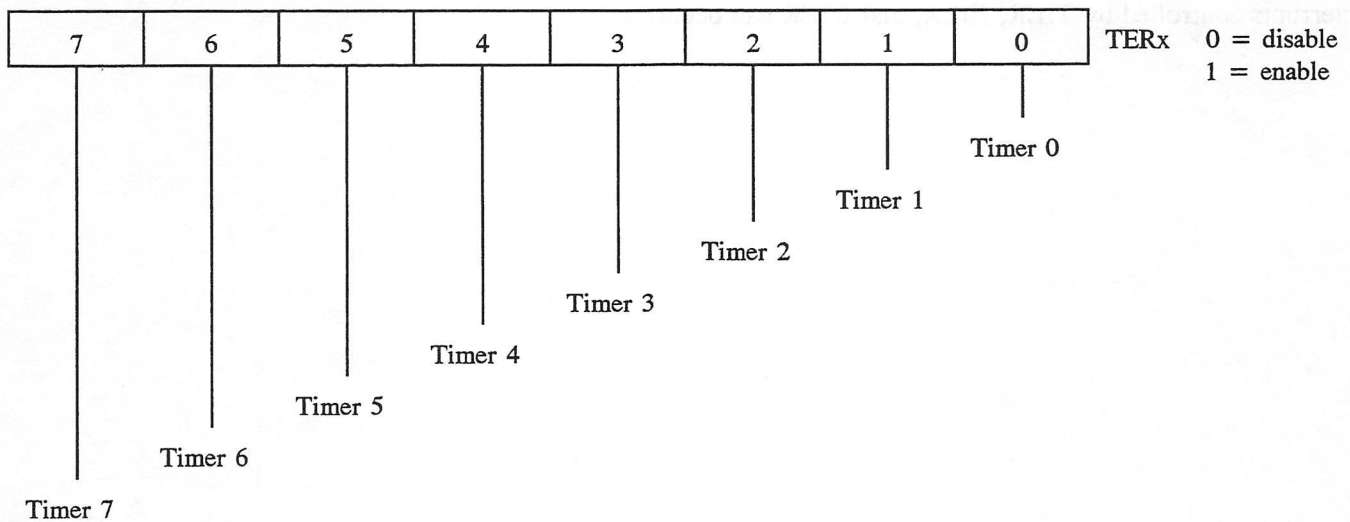

Figure 1-4 Timer Enable Register (TER)

1.6 Interrupt Flag Registers (TIFR,EIFR,UIFR)

- 1.6.1 A bit of these registers is set to a "1" in response to an interrupt signal from a source. Sources specified as level-triggered assert the corresponding IFR bit if an edge occurs and is held to a "1" as long as the IRQB input is held low. Sources specified as edge-triggered assert the corresponding IFR bit upon and only upon transition to the specified polarity. Note that changes for edge-triggered bits are asynchronous with PHI2.
- 1.6.1.1 Read of a IFR register. A read from an IFR register transfers its value to the internal data bus.
- 1.6.1.2 Write to an IFR register. A write of a "1" to any bits of these registers disasserts those bits but has no further effect when execution of that write instruction is completed; that is, the bit is reset by a pulse but not held reset. A write of a "0" to any bits of these registers has no effect. (Note that you must write a "1" to the corresponding IFR bit after the interrupt has been serviced; otherwise, the interrupt will continue to occur.)
- 1.6.1.3 Interrupt Priority. If more than one bit of the Interrupt Flag Registers are set to a "1" and enabled, the vector corresponding to the highest memory map location and bit number asserted is used. For example, if both the TIFR1 and EIFR3 were asserted and enabled, then the vector corresponding to EIFR3 would be used. For another example, if both the TIFR3 and EIFR0 were asserted and enabled, then the vector corresponding to EIFR0 would be used.

1.7 Interrupt Enable Registers (TIER,EIER,UIER)

TIER, EIER, and UIER are the interrupt enable registers. Reading an IER register reads its contents and puts the value on the internal data bus. Writing an IER writes a value from the data bus into the register. Setting a bit in an IER to "1" permits the interrupt corresponding to the same bit in the IFR to cause a processor interrupt. If a WAI instruction has been executed prior to the interrupt occurring and the part is in the non-emulation mode (BCR3=0). The RUN/SYNC pin will be low until the interrupt occurs and will then go high to indicate the part is running.

Note that the "I" flag in the microprocessor status register must be cleared with an instruction before any of the interrupts controlled by TIER, EIER, and UIER can occur.

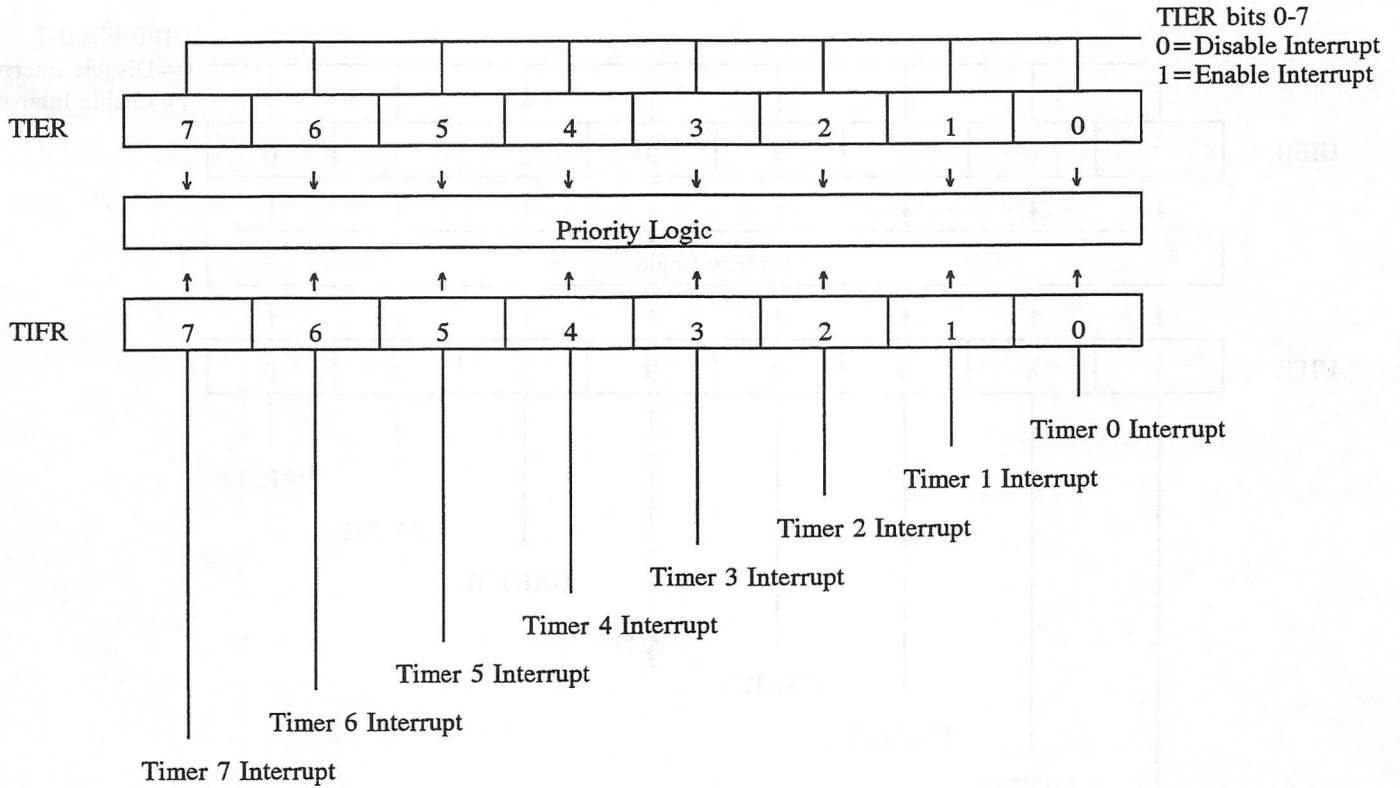

Figure 1-5 Timer Interrupt Enable Register (TIER) and Timer Interrupt Flag Register (TIFR)

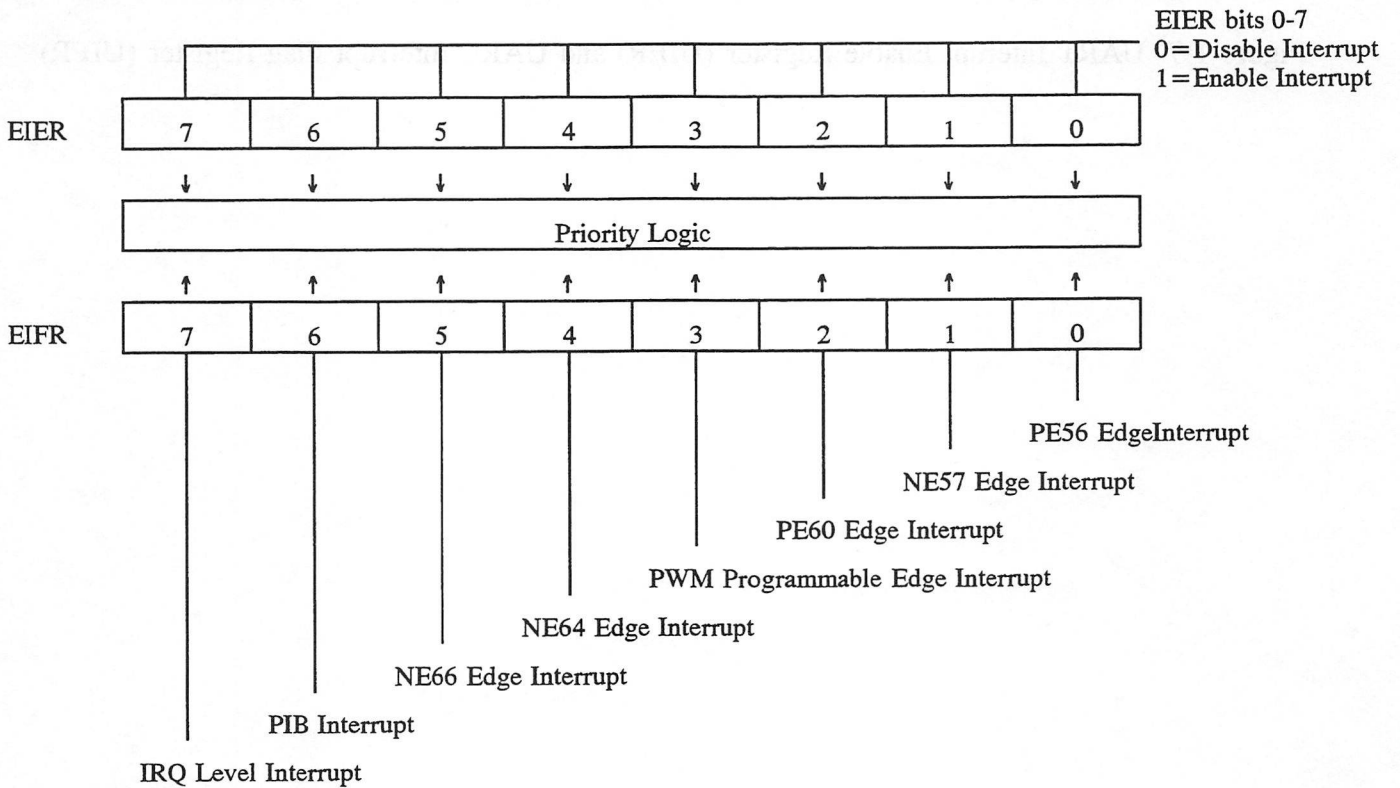

Figure 1-6 Edge Interrupt Enable Register (EIER) and Edge Interrupt Flag Register (EIFR)

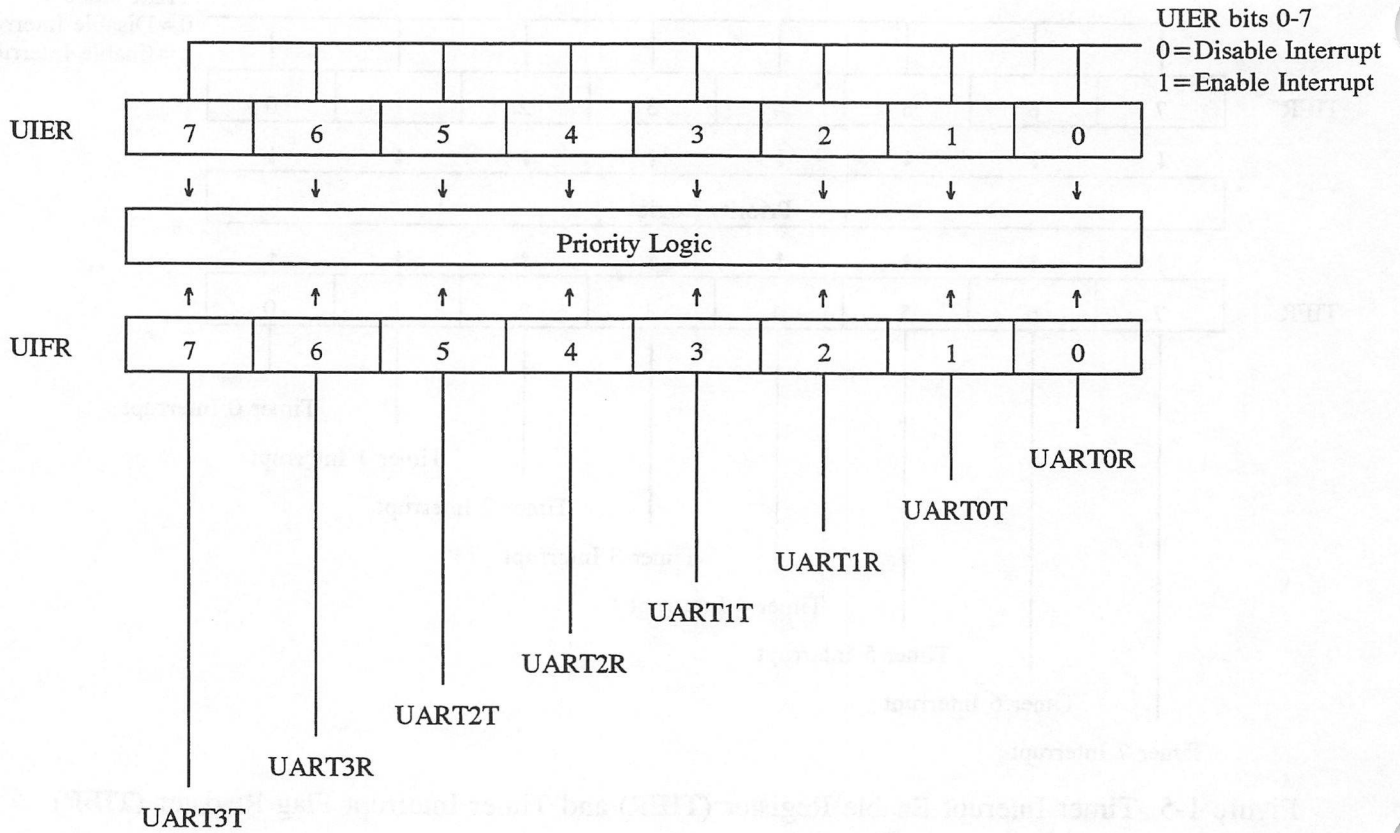

Figure 1-7 UART Interrupt Enable Register (UIER) and UART Interrupt Flag Register (UIFR)

1.8 Asynchronous I/O Data Rate Generation (Timer 3 and 4)

Timer 3 and 4 provide clock timing for the Asynchronous I/O and establishes the data rate for the Serial I/O port. Timer 3 and 4 operate as configured by TCRx and TERx (Timer Control Register and Timer Enable Register) and should be set up prior to enabling the UART.

Table 1-3 identifies the values to be loaded into Timer 3 and 4 to select standard data rates with a clock rate of 4 MHz and 8 MHz. Although Table 1-3 identifies only the more common data rates, any data rate from 1 to 62.5K bps can be selected by using the formula:

$$\text{where } N = \frac{\text{PHI2}}{16 \times \text{bps}} - 1$$

- N decimal value to be loaded in to Timer A using its hexadecimal equivalent
- PHI2 the clock frequency (1MHz or 2MHz was used for Table 1-8)
- bps The desired data rate

Note: One may notice slight differences between the standard rate and the actual data rate. However, transmitter and receiver error of 1.5% or less is acceptable. A revised clock rate is included in Table 1-8 for those baud rates that fall outside this limit.

Table 1-3 Timer 3 and 4 Values for Baud Rate Selection

Standard Baud Rate	Hexadecimal Value (MHz)		Actual Baud Rate at (MHz)		Clock Rate needed to get Standard Baud Rate (MHz)	
	3.579545	4	3.579545	4	3.579545	4
50	1179	1387	50.00	50.00	3.5792	4.000
75	0BA6	0D04	75.00	75.01	3.5796	3.9996
110	07F1	08E0	109.99	109.99	3.57984	4.0005
150	05D2	0682	150.05	149.97	3.5784	4.0008
300	02E9	0340	299.89	300.12	3.5808	3.9984
600	0174	01A0	599.79	599.52	3.5808	4.0032
1200	00B9	00CF	1202.80	1201.92	3.5712	3.9936
2400	005C	0067	2405.61	2403.85	3.5712	3.9936
3600	003D	0044	3608.41	3623.19	3.5712	3.9744
4800	002E	0033	4760.03	4807.69	3.6096	3.9936
7200	001E	0022	7216.82	7142.86	3.5712	4.0320
9600	0016	0019	9727.02	9615.38	3.5328	3.9936

1.9 Universal Asynchronous Receiver/Transmitters (UARTs)

The W65C265S Microcomputer provides four full duplex Universal Asynchronous Receiver/Transmitters (UART) with programmable bit rates. The serial I/O functions are controlled by the Asynchronous Communication Control and Status Registers (ACSRx). The ACSRx bit assignment is shown in Figure 1-10. The serial bit rate is determined by Timer 3 or 4 for all modes for the UART's. The maximum data rate using the internal clock is 0.5MHz bits per second (FCLK = 8MHz). The Asynchronous Transmitter and Asynchronous Receiver can be independently enabled or disabled.

All transmitter and receiver bit rates will occur at one sixteenth of Timer 3 or 4 as selected.

Whenever Timer 3 or 4 is required as a timing source, it must be loaded with the hexadecimal code that selects the data rate for the serial I/O Port. Refer to Table 1-3 for a table of hexadecimal values that represent the desired data rate.

WDC Standard UART Features

- 7 or 8 bit data with or without Odd or Even parity.
- The Transmitter has 1 stop bit with parity or 2 stop bits without parity.
- The Receiver requires only 1 stop bit for all modes.
- Both the Receiver and Transmitter have priority encoded interrupts for service routines.
- The Receiver has error detection for parity error, framing error, or over-run error conditions that may require re-transmission of the message.
- The Receiver Interrupt occurs due to a receiver data register full condition.
- The Transmitter Interrupt can be selected to occur on either the data register empty (end-of-byte transmission) or both the data register empty and the shift register empty (end-of-message transmission) condition.

1.9.1 Asynchronous Transmitter Operation

The transmitter operation is controlled by the Asynchronous Control and Status Register (ACSRx). The transmitter automatically adds a start bit, parity bit and one or two stop bits as defined by the ACSRx. A word of transmitted data is 7 or 8 bits of data.

The Transmitter Data Register (ARTDx) is located at addresses \$DF71, \$DF73, \$DF75, and \$DF77 and is loaded on a write. The Receiver is read at this same address.

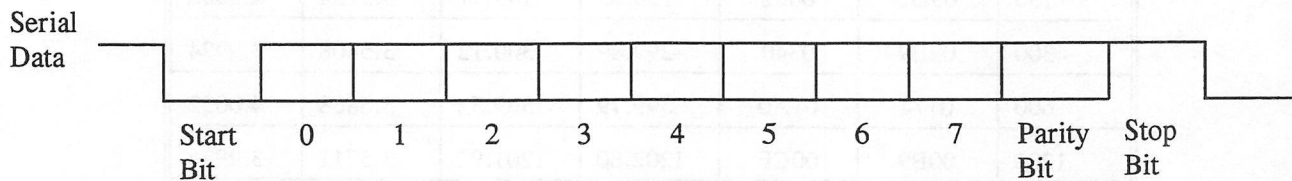

The Transmitter Interrupt is controlled by the Asynchronous Control Status Register bit ACSRx1.

$IRQAT = ACSRx0((ACSRx1B)(DATA REGISTER EMPTY) + (ACSRx1)(DATA REGISTER AND SHIFT REGISTER EMPTY))$

Figure 1-8 Asynchronous Transmitter Mode with Parity

1.9.2 Asynchronous Receiver Operation

The receiver and its selected control and status functions are enabled when ACSR_{x5} is set to a "1". The data format must have a start bit, 7 or 8 data bits, and one stop bit or one parity bit and one stop bit. The receiver bit period is divided into 16 sub-intervals for internal synchronization. The receiver bit stream is synchronized by the start bit, and a strobe signal is generated at the approximate center of each incoming bit. The character assembly process does not start if the start bit signal is less than one-half the bit time after a low level is detected on the Receive Data Input. A framing error, parity error or an over-run will set ACSR_{x7} the receiver error detection bit. An over-run condition occurs when the receiver data register has not been read and new data byte is transferred from the receiver shift register.

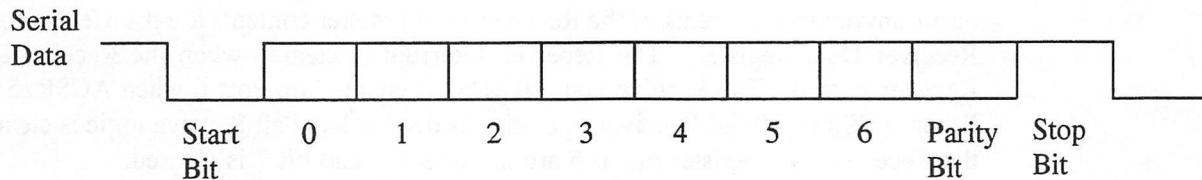

Note: The receiver requires only one stop bit but the transmitter supplies two stop bits for older system timing.

Figure 1-9 Asynchronous Data Timing for 7-bit Data without Parity

A receiver interrupt (IRQAR_x) is generated whenever the receiver shift register is transferred to the receiver data register.

1.9.3 Asynchronous Control and Status Registers (ACSR_x)

The Asynchronous Control and Status Register (ACSR_x) enables the Receiver and Transmitter and holds information on communication status error conditions.

Bit assignments and function of the ACSR_x are as follows:

- ACSR_{x0}: Transmitter Enable. The Asynchronous Transmitter is enabled, the Transmitter Interrupt (IRQAT_x), and TXD_x is enabled on P61, P63, P65 or P67 when ACSR_{x0}=1. When ACSR_{x0} is cleared, the ACSR_{x1} is cleared, the transmitter will be disabled, the Transmitter Interrupt will not occur and TXD_x will be disabled on P61, P63, P65 or P67. This bit is cleared by a RESET.
- ACSR_{x1}: Transmitter Interrupt Source Select. When ACSR_{x1}=0, the Transmitter Interrupt occurs due to a Transmitter Data Register Empty condition (end-of-byte transmission). When ACSR_{x1}=1 the Transmitter Interrupt occurs due to both the Transmitter Data and Shift register empty condition (end-of-message transmission). The Transmitter Interrupt is cleared by writing to the Transmitter Data Register.
- ACSR_{x2}: Seven- or Eight-Bit Data Select. When ACSR_{x2}=0, the Transmitter and Receiver send and receive 7-bit data. The Transmitter sends a total of 10 bits of information (one start, 7 data, one parity and one stop or 2 stop bits). The Receiver receives 9 or 10 bits of information (one start, 7 data, and one stop or one stop and one parity bits). When writing to the Transmitter in seven bit mode, bit 7 is discarded. When

reading from the receive data register during seven bit mode, bit 7 is always zero. When ACSRx2=1, the Transmitter and Receiver send and receive 8-bit data. The Transmitter sends 11 bits of information (one start, 8 data, one parity and one stop or two stop bits). The Receiver receives 10 or 11 bits of information (one start, 8 data, one stop or one parity and one stop bit). Reset clears ACSRx2.

- ACSRx3: Parity Enable. When ACSRx3=0, parity is disabled. Reset clears ACSRx3. When ACSRx3=1, parity is enabled for both the Transmitter and Receiver.
- ACSRx4: Odd or Even Parity. When ACSRx4=0 and parity is enabled, then Odd parity is generated where the number of ones in the data register plus parity bit equal an odd number of "1's". When ACSRx4=1 and parity is enabled, then Even parity is generated where the number of ones in the data register plus parity bit equal an even number of "1's". ACSRx4 is cleared by Reset.
- ACSRx5: Receiver Enable. The Asynchronous Receiver is enabled when ACSRx5=1. Reset clears ACSRx5. When ACSRx5=1 the Receiver is enabled and Receiver Interrupts occur anytime the contents of the Receiver shift register contents are transferred to the Receiver Data Register. The Receiver Interrupt is cleared when the Receive Data Register is read. The Receive Data, RXDx, is enabled on Port 6 when ACSRx5=1. When ACSRx5=0, all Receiver operation is disabled and all Receive logic is cleared, the Receiver data register bits 0-6 are not affected and bit 7 is cleared.
- ACSRx6: Software Semaphore. ACSRx6 may be used for communications among routines which access the UARTx. This bit has no effect on the UART operation and is cleared upon Reset. The bit can be thought of as a UART 'busy' signal.
- ACSRx7: Receiver Error Flag. The Receiver logic detects three possible error conditions and sets ACSRx7: parity, framing or over-run. A parity error occurs when the parity bit received does not match the parity generated on the receive data. A framing error occurs when the stop bit time finds a "0" instead of a "1". An over-run occurs when the last data in the Receiver Data Register has not been read and new data is transferred from the Receive Shift Register. ACSRx7 is cleared by Reset or upon writing a "1" to ACSRx7. Writing a "0" to ACSR7 has not effect on ACSRx7.

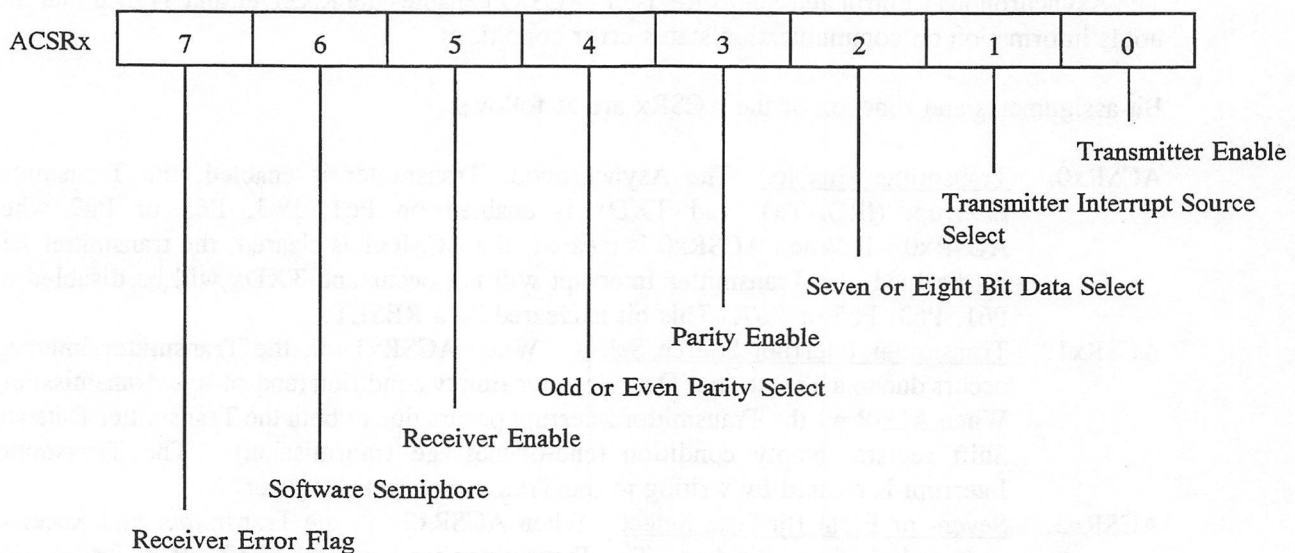

Figure 1-10 ACSRx Bit Assignments

1.10 The Parallel Interface Bus (PIB)

The Parallel Interface Bus (PIB) is used to communicate instructions and data to and from task oriented processors, smart peripherals, co-processors, and parallel processors.

PIRS 2,1,0 Register Address		
111	7	Automatic Handshake
110	6	
101	5	
100	4	
011	3	Automatic Handshake
010	2	
001	1	PIB Enable Register (PIBER)
000	0	PIB Flag Register (PRBFR)

Register 3 may have a primary role of communicating commands or opcodes between processors.
Register 7 may have a primary role of communicating data or addresses between processors.

Figure 1-11 The PIB Registers

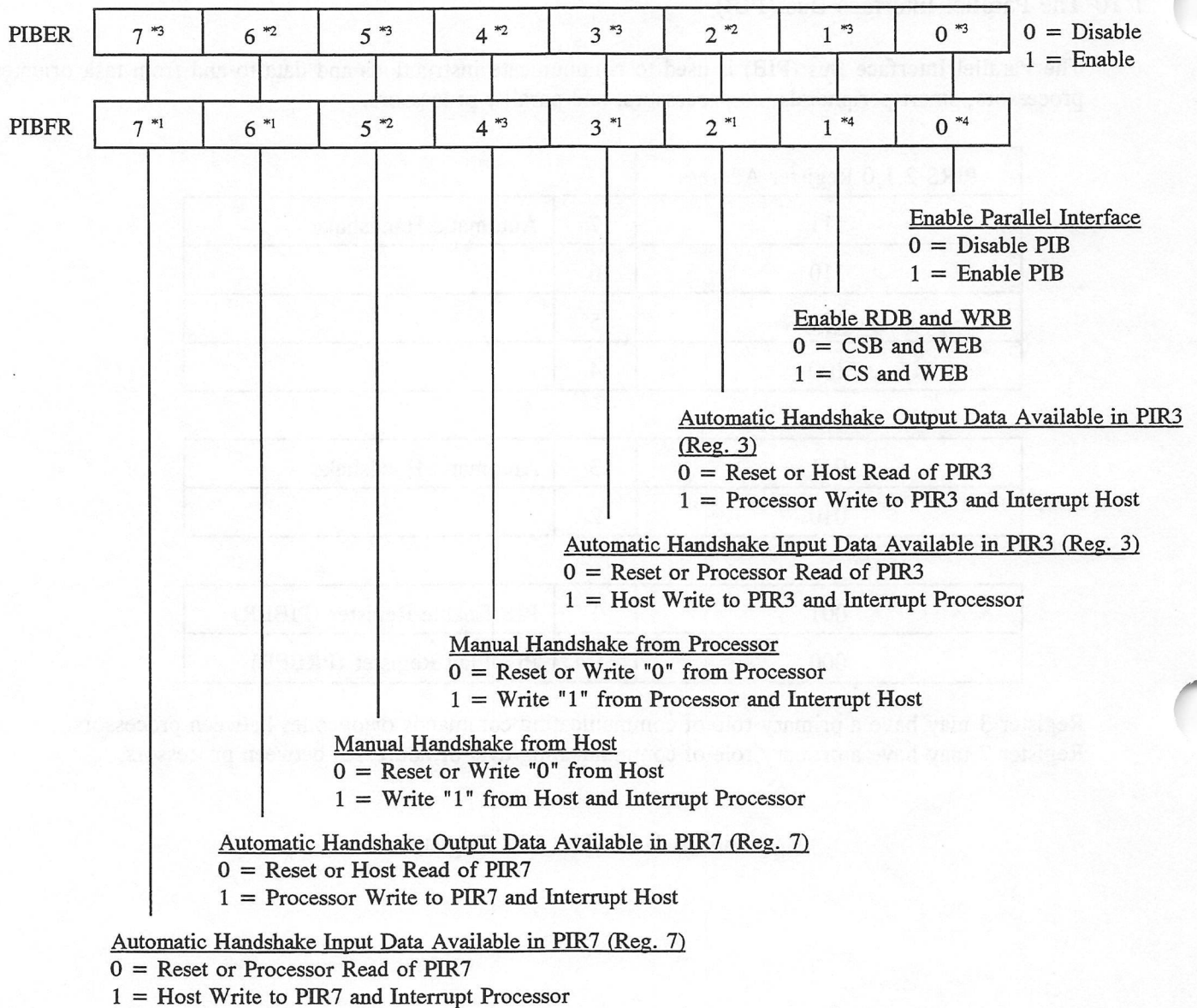

- Notes:
- *1 Read only from Host or Processor
 - *2 Read only from Processor, Read or Write from Host
 - *3 Read only from Host, Read or Write from Processor
 - *4 Read only from Host or Processor, will always read back a zero.

Figure 1-12 Parallel Interface Bus Enable (PIBER) and Flag (PIBFR) Registers

1.11 Twin Tone Generators

Each Tone Generator(TGx), as shown in figure 1-13 is comprised of a 16 bit timer and a 16 step divider circuit that selects the proper Digital to Analog (DA) output level. The enable bits for the tone generators are located in bits 1 and 2 of the BCR registers (see Figure 1-2).

$$DA \text{ Level } n = E \cos \left(\pi \times \frac{(2n+1)}{16} \right) \quad 0 \leq n \leq 7$$

N=value loaded into timer latches
 F=desired frequency
 FCLK=FCLK input clock

$$\text{Register Value } N = \frac{FCLK}{16 \times F} - 1$$

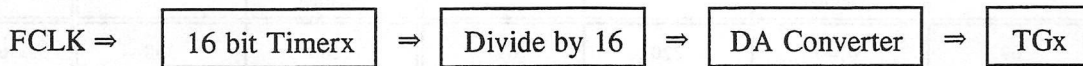

Figure 1-13 Tone Generator Block Diagram

Table 1-4 Communications Frequencies Generated by the Tone Generator Timers 5 and 6

	Standard Frequency (Hz)	Oscillator FCLK = 3.579545 MHz			Oscillator FCLK = 4.000000 MHz		
		Register Value		Actual Frequency (Hz)	Register Value		Actual Frequency (Hz)
		Hexi-decimal	Decimal		Hexi-decimal	Decimal	
DTMF Row	697	0140	320	697	0166	358	696
	770	0122	290	769	0144	324	769
	852	0106	262	851	0124	292	853
	941	00ED	237	940	0109	265	940
DTMF Column	1209	00B8	184	1209	00CE	206	1208
	1336	00A6	166	1340	00BA	186	1337
	1477	0096	150	1482	00AB	168	1479
	1633	0088	136	1633	0098	152	1634
Subscriber Tones	350	027E	638	350	02C9	713	350
	440	01FB	507	440	0237	567	440
	480	01D1	465	480	0208	520	480
	620	0168	360	620	0192	402	620
US 110, 300 Baud Modem	1070	00D0	208	1070	00E9	233	1068
	1270	00AF	175	1271	00C4	196	1269
	2025	006D	109	2034	007A	122	2033
	2225	0064	100	2215	006F	111	2232
European 110, 300 Baud Modem	980	00E3	227	981	00FE	254	980
	1180	00BD	189	1177	00D3	211	1179
	1650	0087	135	1645	0097	151	1645
	1850	0078	120	1849	0086	134	1832
Teletext	390	023D	573	390	0280	640	390
	450	01F0	496	450	022B	555	450
	1300	00AB	171	1301	00BF	191	1302
	2100	006A	106	2091	0076	118	2101
US 1200 Baud Modem	390	023D	573	390	0280	640	390
	450	01F0	496	450	022B	555	450
	1200	00B9	185	1203	00CF	207	1202
	2200	0065	101	2193	0071	113	2193

1.12 Processor Defined Cache Control

The Processor Defined Cache Control allows the W65C265S to slow its clock rate. The idea of cache with the W65C265S is that all memory running at the FCLK rate is cache memory. When slower memories are addressed, the PHI2 clock rate is slowed. PHI2 is slowed by extending the PHI2 low and high times. Whether or not the clock rate is slowed down is determined by the System Speed Control (SSCR) Register.

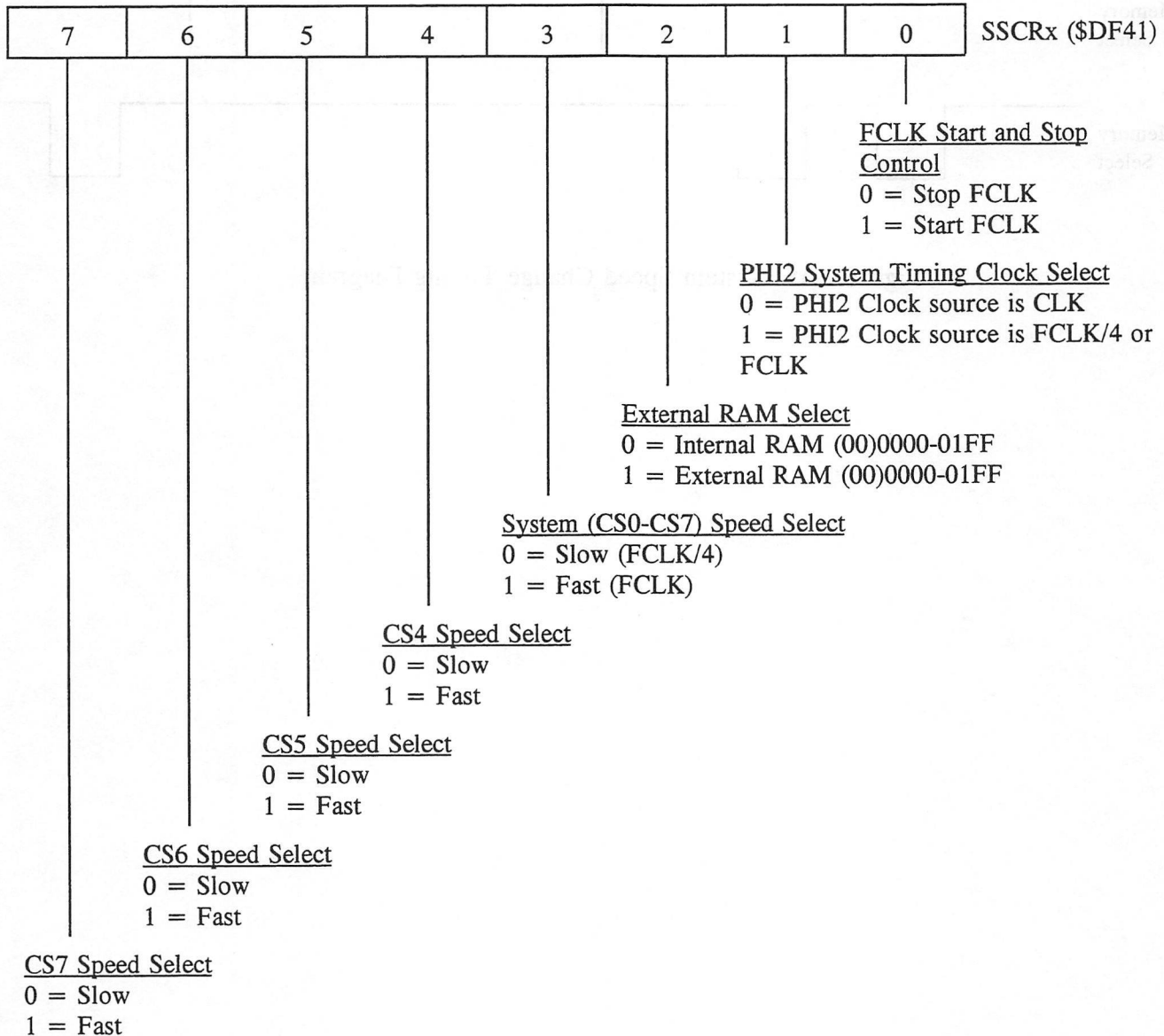

Figure 1-14 System Speed Control Register (SSCR)

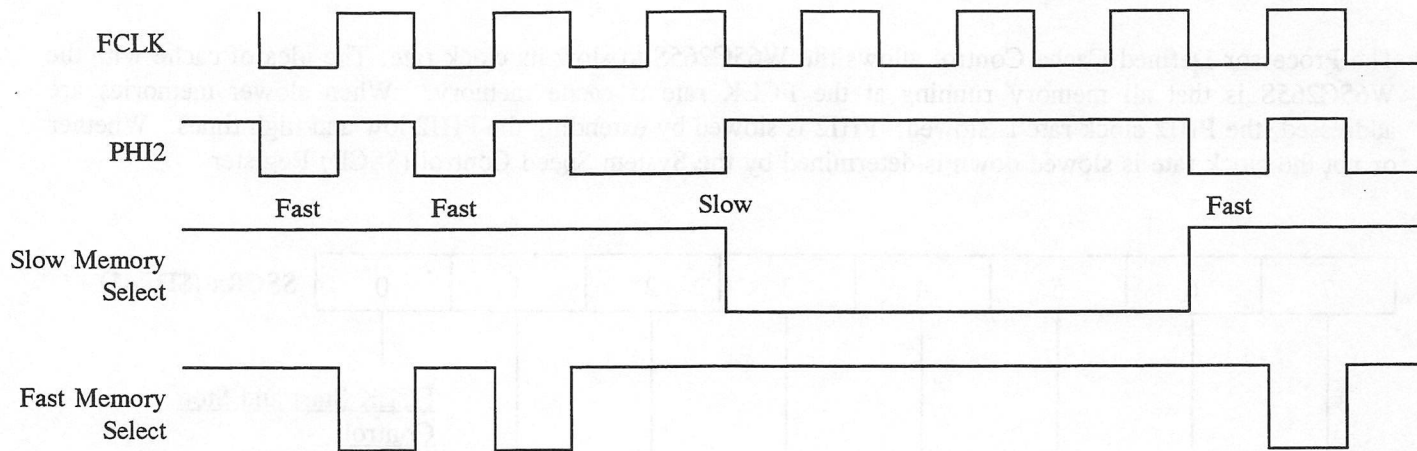

Figure 1-15 System Speed Change Timing Diagram

1.13 Programming Model and Memory Map

The W65C816S Microprocessor Programming Model, System Memory Map, I/O Memory Map, Vector Table, and Pin Map summarize the W65C265S Programming Model and gives the functional area where each memory and pin is defined.

The W65C265S completely decodes the entire 16M byte address space of the on-chip W65C816S microprocessor. The System Memory Map is shown in Table 1-5. The on-chip I/O, Timers, Control Registers, Shift Registers, Interrupt Registers, and Data Registers are presented in Table 1-6A through 1-6D, I/O Memory Map, Control and Status Register Memory Map, Timer Register Memory Map, and Communication Memory Map. The W65C265S has twenty-nine (29) priority encoded interrupts whose vector addresses are listed in Table 1-7A and B, Vector Table.

8 BITS	8 BITS	8 BITS
Data Bank Register (DBR)	X Register High (XH)	X Register Low (XL)
Data Bank Register (DBR)	Y Register High (YH)	Y Register Low (YL)
00	Stack Register High (SH)	Stack Register Low (SL)
	Accumulator (B)	Accumulator (A)
Program Bank Register (PBR)	Program (PCH)	Counter (PCL)
00	Direct Register High (DH)	Direct Register Low (DL)

Shaded blocks = 6502 registers

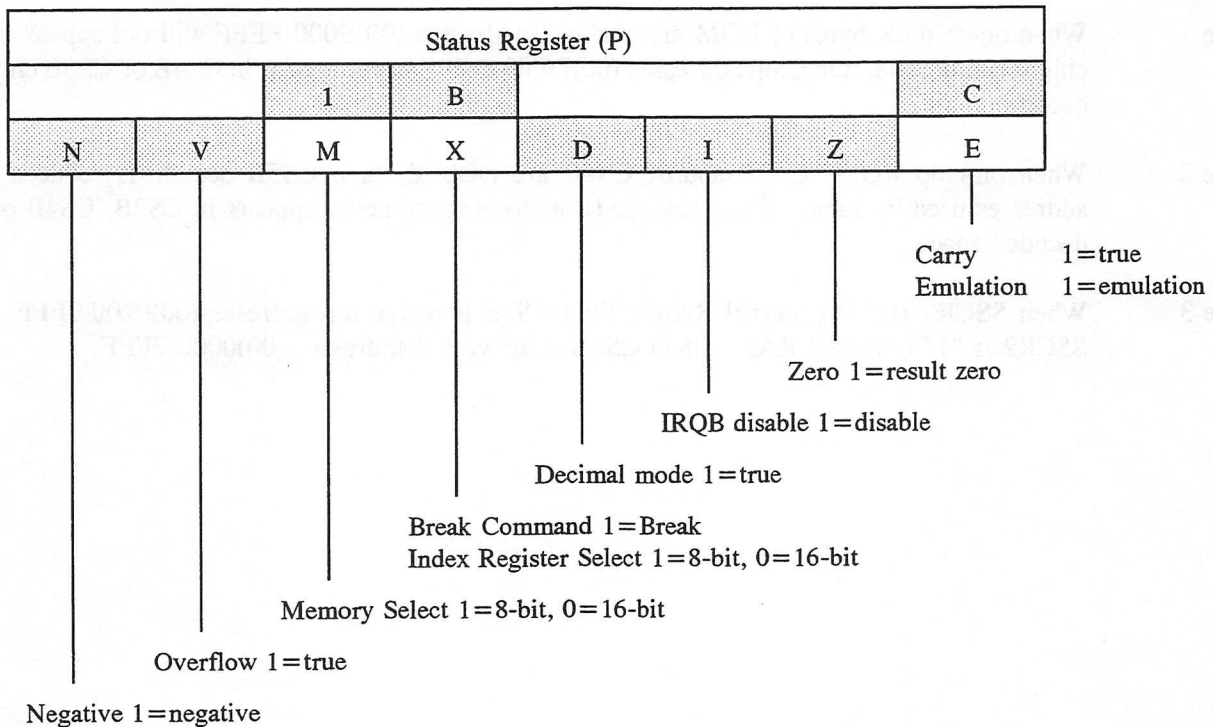

Figure 1-16 W65C816S Programming Model and Memory Map

Table 1-5 System Memory Map

Chip Select	Block Size	Address Range	Function
CS7B	4M	(CO-FF)	User Memory
CS6B	8M	(40-BF)	User Memory
CS5B	4M	(00-3F)	Memory (Note 2)
CS4B	8192 24320	(00)E000-FFFF (00)8000-DEFF	ROM Memory (Note 1) ROM Memory (Note 1)
CS3B	32256	(00)0200-7FFF	Cache Memory (Note 3)
CS2B	256 7936 64 16 32 16 8 8 512	(00)FF00-FFFF (00)E000-FE00 (00)DF80-DFBF (00)DF70-FF7F (00)DF50-FF6F (00)DF40-FF4F (00)DF20-DF27 (00)DF00-DF07 (00)0000-01FF	On-chip Interrupt Vectors On-chip ROM On-chip RAM On-chip Comm. Registers On-chip Timer Registers On-chip Control Registers On-chip I/O Registers On-chip I/O Registers On-chip RAM
CS1B	64	(00)DFC0-DFFF	COProcessor expansion
CS0B	32	(00)DF00-DF1F	Port replacement & Expansion

- Note 1. When on-chip 8K bytes of ROM are enabled, addresses (00)E000-FFFF will not appear in CS4B chip select decode. On Chip addresses (00)DF00-DFFF never appear in CS4B or CS5B chip select decode.
- Note 2. When on-chip ROM, CS3B and/or CS4B are enabled, then CS5B decode is reduced by the addresses used by same. CS0B and CS1B address space never appears in CS2B, CS4B or CS5B decoded space.
- Note 3. When SSCR2 is "0" (internal RAM), then CS3B is active for addresses(00)0200-7FFF. When SSCR2 is "1" (external RAM), then CS3B is active for addresses (00)0000-7FFF.

Table 1-6A I/O Register Memory Map

Address	Label	Function	Reset Value
00DFC0-FF	CS1	COProcessor Expansion	uninitialized
00DF28-3F	---	Reserved	uninitialized
00DF27	PCS7	Port 7 Chip Select	\$00
00DF26	PDD6	Port 6 Data Direction Register	\$00
00DF25	PDD5	Port 5 Data Direction Register	\$00
00DF24	PDD4	Port 4 Data Direction Register	\$00
00DF23	PD7	Port 7 Data Register	\$FF
00DF22	PD6	Port 6 Data Register	\$00
00DF21	PD5	Port 5 Data Register	\$00
00DF20	PD4	Port 4 Data Register	\$00
00DF08-1F	CS0	Port Replacement & Expansion	uninitialized
00DF07	PDD3	Port 3 Data Direction Register	\$00
00DF06	PDD2	Port 2 Data Direction Register	\$00
00DF05	PDD1	Port 1 Data Direction Register	\$00
00DF04	PDD0	Port 0 Data Direction Register	\$00
00DF03	PD3	Port 3 Data Register	\$00
00DF02	PD2	Port 2 Data Register	\$00
00DF01	PD1	Port 1 Data Register	\$00
00DF00	PD0	Port 0 Data Register	\$00

Table 1-6B Control and Status Register Memory Map

Address	Label	Function	Reset Value
00DF4A-4F	---	Reserved	uninitialized
00DF49	UIER	UART Interrupt Enable Register	\$00
00DF48	UIFR	UART Interrupt Flag Register	\$00
00DF47	EIER	Edge Interrupt Enable Register	\$00
00DF46	TIER	Timer Interrupt Enable Register	\$00
00DF45	EIFR	Edge Interrupt Flag Register	\$00
00DF44	TIFR	Timer Interrupt Flag Register	\$00
00DF43	TER	Timer Enable Register	\$00
00DF42	TCR	Timer Control Register	\$00
00DF41	SSCR	System Speed Control Register	\$00
00DF40	BCR	Bus Control Register	\$00/\$89

Table 1-6C Timer Register Memory Map

Address	Label	Function	Reset Value
00DF6F	T7CH	Timer 7 Counter High	uninitialized
00DF6E	T7CL	Timer 7 Counter Low	uninitialized
00DF6D	T6CH	Timer 6 Counter High	uninitialized
00DF6C	T6CL	Timer 6 Counter Low	uninitialized
00DF6B	T5CH	Timer 5 Counter High	uninitialized
00DF6A	T5CL	Timer 5 Counter Low	uninitialized
00DF69	T4CH	Timer 4 Counter High	uninitialized
00DF68	T4CL	Timer 4 Counter Low	uninitialized
00DF67	T3CH	Timer 3 Counter High	uninitialized
00DF66	T3CL	Timer 3 Counter Low	uninitialized
00DF65	T2CH	Timer 2 Counter High	uninitialized
00DF64	T2CL	Timer 2 Counter Low	uninitialized
00DF63	T1CH	Timer 1 Counter High	uninitialized
00DF62	T1CL	Timer 1 Counter Low	uninitialized
00DF61	T0CH	Timer 0 Counter High	uninitialized
00DF60	T0CL	Timer 0 Counter Low	uninitialized
00DF5F	T7LH	Timer 7 Latch High	uninitialized
00DF5E	T7LL	Timer 7 Latch Low	uninitialized
00DF5D	T6LH	Timer 6 Latch High	uninitialized
00DF5C	T6LL	Timer 6 Latch Low	uninitialized
00DF5B	T5LH	Timer 5 Latch High	uninitialized
00DF5A	T5LL	Timer 5 Latch Low	uninitialized
00DF59	T4LH	Timer 4 Latch High	uninitialized
00DF58	T4LL	Timer 4 Latch Low	uninitialized
00DF57	T3LH	Timer 3 Latch High	uninitialized
00DF56	T3LL	Timer 3 Latch Low	uninitialized
00DF55	T2LH	Timer 2 Latch High	uninitialized
00DF54	T2LL	Timer 2 Latch Low	uninitialized
00DF53	T1LH	Timer 1 Latch High	uninitialized
00DF52	T1LL	Timer 1 Latch Low	uninitialized
00DF51	T0LH	Timer 0 Latch High	uninitialized
00DF50	T0LL	Timer 0 Latch Low	uninitialized

Table 1-6D Communication Register Memory Map

Address	Label	Function	Reset Value
00DF80-BF	RAM	RAM Registers	uninitialized
00DF7F	PIR7	Parallel Interface Register 7	uninitialized
00DF7E	PIR6	Parallel Interface Register 6	uninitialized
00DF7D	PIR5	Parallel Interface Register 5	uninitialized
00DF7C	PIR4	Parallel Interface Register 4	uninitialized
00DF7B	PIR3	Parallel Interface Register 3	uninitialized
00DF7A	PIR2	Parallel Interface Register 2	uninitialized
00DF79	PIBER	Parallel Interface Enable Reg.	\$00
00DF78	PIBFR	Parallel Interface Flag Reg.	\$00
00DF77	ARTD3	UART 3 Data Register	uninitialized
00DF76	ACSR3	UART 3 Control/Status Register	\$00
00DF75	ARTD2	UART 2 Data Register	uninitialized
00DF74	ACSR2	UART 2 Control/Status Register	\$00
00DF73	ARTD1	UART 1 Data Register	uninitialized
00DF72	ACSR1	UART 1 Control/Status Register	\$00
00DF71	ARTD0	UART 0 Data Register	uninitialized
00DF70	ACSRO	UART 0 Control/Status Register	\$00

Table 1-7A Emulation Mode Vector Table

Address	Label	Function
00FFFE,F	IRQBRK	BRK - Software Interrupt
00FFFC,D	IRQRES	RES - "REStart" Interrupt
00FFFA,B	IRQNMI	Non-Maskable Interrupt
00FFF8,9	IABORT	ABORT Interrupt
00FFF6,7	IRQRVD	Reserved
00FFF4,5	IRQCOP	COP Software Interrupt
00FFF2,3	IRQRVD	Reserved
00FFF0,1	IRQRVD	Reserved
00FFEE,F	IRQAT3	UART3 Transmitter Interrupt
00FFEC,D	IRQAR3	UART3 Receiver Interrupt
00FFEA,B	IRQAT2	UART2 Transmitter Interrupt
00FFE8,9	IRQAR2	UART2 Receiver Interrupt
00FFE6,7	IRQAT1	UART1 Transmitter Interrupt
00FFE4,5	IRQAR1	UART1 Receiver Interrupt
00FFE2,3	IRQAT0	UART0 Transmitter Interrupt
00FFE0,1	IRQAR0	UART0 Receiver Interrupt
00FFDE,F	IRQ	IRQ Level Interrupt
00FFDC,D	IRQPIB	Parallel Interface Bus (PIB) Interrupt
00FFDA,B	IRNE66	Negative Edge Interrupt on P66
00FFD8,9	IRNE64	Negative Edge Interrupt on P64
00FFD6,7	IRPE62	Positive Edge Interrupt on P62 for PWM
00FFD4,5	IRPE60	Positive Edge Interrupt on P60
00FFD2,3	IRNE57	Negative Edge Interrupt on P57
00FFD0,1	IRPE56	Positive Edge Interrupt on P56
00FFCE,F	IRQT7	Timer 7 Interrupt
00FFCC,D	IRQT6	Timer 6 Interrupt
00FFCA,B	IRQT5	Timer 5 Interrupt
00FFC8,9	IRQT4	Timer 4 Interrupt
00FFC6,7	IRQT3	Timer 3 Interrupt
00FFC4,5	IRQT2	Timer 2 Interrupt
00FFC2,3	IRQT1	Timer 1 Interrupt
00FFC0,1	IRQT0	Timer 0 Interrupt

Table 1-7B Native Mode Vector Table

Address	Label	Function
00FFBE,F	IRQRVD	Reserved
00FFBC,D	IRQRVD	Reserved
00FFBA,B	IRQNMI	Non-Maskable Interrupt
00FFB8,9	IABORT	ABORT Interrupt
00FFB6,7	IRQBRK	BRK Software Interrupt
00FFB4,5	IRQCOP	COP Software Interrupt
00FFB2,3	IRQRVD	COP Software Interrupt
00FFB0,1	IRQRVD	Reserved
00FFAE,F	IRQAT3	UART3 Transmitter Interrupt
00FFAC,D	IRQAR3	UART3 Receiver Interrupt
00FFAA,B	IRQAT2	UART2 Transmitter Interrupt
00FFA8,9	IRQAR2	UART2 Receiver Interrupt
00FFA6,7	IRQAT1	UART1 Transmitter Interrupt
00FFA4,5	IRQAR1	UART1 Receiver Interrupt
00FFA2,3	IRQAT0	UART0 Transmitter Interrupt
00FFA0,1	IRQAR0	UART0 Receiver Interrupt
00FF9E,F	IRQ	IRQ Level Interrupt
00FF9C,D	IRQPIB	Parallel Interface Bus (PIB) Interrupt
00FF9A,B	IRNE66	Negative Edge Interrupt on P66
00FF98,9	IRNE64	Negative Edge Interrupt on P64
00FF96,7	IRPE62	Positive Edge Interrupt on P62 for
00FF94,5	IRPE60	Positive Edge Interrupt on P60
00FF92,3	IRNE57	Negative Edge Interrupt on P57
00FF90,1	IRPE56	Positive Edge Interrupt on P56
00FF8E,F	IRQT7	Timer 7 Interrupt
00FF8C,D	IRQT6	Timer 6 Interrupt
00FF8A,B	IRQT5	Timer 5 Interrupt
00FF88,9	IRQT4	Timer 4 Interrupt
00FF86,7	IRQT3	Timer 3 Interrupt
00FF84,5	IRQT2	Timer 2 Interrupt
00FF82,3	IRQT1	Timer 1 Interrupt
00FF80,1	IRQT0	Timer 0 Interrupt
00FF00-7F	IRQRVD	Reserved

Table 1-8A W65C265S 84 Lead Pin Map (continued on next 3 pages)

Pin	Name	Control Bit	Signal with Control Bit=0	Signal with Control Bit=1
1	VSS	---	VSS	VSS
2	P56/PE56/ PID6	BCR4 PIBER0	P56	PE56 PID6
3	P57/NE57/ PID7	BCR4 PIBER0	P57	NE57 PID7
4	P60/RXD0/ TIN	ACSR05 TCR1	P60	RXD0 TIN
5	P61/TXD0/ TOUT	ACSR00 TCR0	P61	TXD0 TOUT
6	P62/RXD1/ PWM	ACSR15 TCR2+TCR3	P62	RXD1 PWM
7	P63/TXD1/ TOUT	ACSR10	P63	TXD1
8	P64/RXD2	ACSR25	P64	RXD2
9	P65/TXD2	ACSR20	P65	TXD2
10	P66/RXD3	ACSR35	P66	RXD3
11	P67/TXD3	ACSR30	P67	TXD3
12	RESB	---	RESB	RESB
13	WEB	---	WEB	WEB
14	RUN/SYNC	BCR3	RUN	RUN/SYNC
15	FCLKOB	---	FCLKOB	FCLKOB
16	FCLK	---	FCLK	FCLK
17	BE/RDY	---	BE/RDY	BE/RDY
18	CLK	---	CLK	CLK
19	CLKOB	---	CLKOB	CLKOB
20	PHI2	---	PHI2	PHI2
21	BA/DODB	BCR3	BA/1	BA/DODB
22	VSS	---	VSS	VSS
23	VDD	---	VDD	VDD
24	P00/A0	BCR0	P00	A0
25	P01/A1	BCR0	P01	A1
26	P02/A2	BCR0	P02	A2

27	P03/A3	BCR0	P03	A3
28	P04/A4	BCR0	P04	A4
29	P05/A5	BCR0	P05	A5
30	P05/A6	BCR0	P06	A6
31	P07/A7	BCR0	P07	A7
32	P10/A8	BCR0	P10	A8
33	P11/A9	BCR0	P11	A9
34	P12/A10	BCR0	P12	A10
35	P13/A11	BCR0	P13	A11
36	P14/A12	BCR0	P14	A12
37	P15/A13	BCR0	P15	A13
38	P16/A14	BCR0	P16	A14
39	P17/A15	BCR0	P17	A15
40	P30/A16	BCR0	P30	A16
41	P31/A17	BCR0	P31	A17
42	P32/A18	BCR0	P32	A18
43	VSS	---	VSS	VSS
44	VDD	---	VDD	VDD
45	P33/A19	BCR0	P33	A19
46	P34/A20	BCR0	P34	A20
47	P35/A21	BCR0	P35	A21
48	P36/A22	BCR0	P36	A22
49	P37/A23	BCR0	P37	A23
50	P70/CS0B	PCS70	P70	CS0B
51	P71/CS1B	PCS71	P71	CS1B
52	P72/CS2B	PCS72	P72	CS2B
53	P73/CS3B	PCS73	P73	CS3B
54	P74/CS4B	PCS74	P74	CS4B
55	P75/CS5B	PCS75	P75	CS5B
56	P76/CS6B	PCS76	P76	CS6B
57	P76/CS7B	PCS77	P77	CS7B
58	P20/D0	BCR0	P20	D0
59	P21/D1	BCR0	P21	D1
60	P22/D2	BCR0	P22	D2
61	P23/D3	BCR0	P23	D3
62	P24/D4	BCR0	P24	D4
63	VDD	---	VDD	VDD

64	VSS	---	VSS	VSS
65	P25/D5	BCR0	P25	D5
66	P26/D6	BCR0	P26	D6
67	P27/D7	BCR0	P27	D7
68	TG0	TCR31	---	TG0
69	TG1	TCR33	---	TG1
70	P40/NMIB/ ABORTB	BCR5 · BCR6 BCR5 · BCR6B	P40	NMIB ABORTB
71	P41/IRQB	EIER3	P41	IRQB
72	P42/PIIB	PIBER0	P42	PIIB
73	P43/PIWEB/ PIWRB	PIBER0 · PIBER1B PIBER0 · PIBER1	P43	PIWEB PIWRB
74	P44/PICSB/ PIRDB	PIBER0 · PIBER1B PIBER0 · PIBER1	P44	PICSB PIRDB
75	P45/PIRS0	PIBER0	P45	PIRS0
76	P46/PIRS1	PIBER0	P46	PIRS1
77	P47/PIRS2	PIBER0	P47	PIRS2
78	P50/PID0	PIBER0	P50	PID0
79	P51/PID1	PIBER0	P51	PID1
80	P52/PID2	PIBER0	P52	PID2
81	P53/PID3	PIBER0	P53	PID3
82	P54/PID4	PIBER0	P54	PID4
83	P55/PID5	PIBER0	P55	PID5
84	VDD	---	VDD	VDD

1	1903	1903	1903
2	1903	1903	1903
3	1903	1903	1903
4	1903	1903	1903
5	1903	1903	1903
6	1903	1903	1903
7	1903	1903	1903
8	1903	1903	1903
9	1903	1903	1903
10	1903	1903	1903
11	1903	1903	1903
12	1903	1903	1903
13	1903	1903	1903
14	1903	1903	1903
15	1903	1903	1903
16	1903	1903	1903
17	1903	1903	1903
18	1903	1903	1903
19	1903	1903	1903
20	1903	1903	1903
21	1903	1903	1903
22	1903	1903	1903
23	1903	1903	1903
24	1903	1903	1903
25	1903	1903	1903
26	1903	1903	1903
27	1903	1903	1903
28	1903	1903	1903
29	1903	1903	1903
30	1903	1903	1903
31	1903	1903	1903
32	1903	1903	1903
33	1903	1903	1903
34	1903	1903	1903
35	1903	1903	1903
36	1903	1903	1903
37	1903	1903	1903
38	1903	1903	1903
39	1903	1903	1903
40	1903	1903	1903
41	1903	1903	1903
42	1903	1903	1903
43	1903	1903	1903
44	1903	1903	1903
45	1903	1903	1903
46	1903	1903	1903
47	1903	1903	1903
48	1903	1903	1903
49	1903	1903	1903
50	1903	1903	1903
51	1903	1903	1903
52	1903	1903	1903
53	1903	1903	1903
54	1903	1903	1903
55	1903	1903	1903
56	1903	1903	1903
57	1903	1903	1903
58	1903	1903	1903
59	1903	1903	1903
60	1903	1903	1903
61	1903	1903	1903
62	1903	1903	1903
63	1903	1903	1903
64	1903	1903	1903
65	1903	1903	1903
66	1903	1903	1903
67	1903	1903	1903
68	1903	1903	1903
69	1903	1903	1903
70	1903	1903	1903
71	1903	1903	1903
72	1903	1903	1903
73	1903	1903	1903
74	1903	1903	1903
75	1903	1903	1903
76	1903	1903	1903
77	1903	1903	1903
78	1903	1903	1903
79	1903	1903	1903
80	1903	1903	1903
81	1903	1903	1903
82	1903	1903	1903
83	1903	1903	1903
84	1903	1903	1903
85	1903	1903	1903
86	1903	1903	1903
87	1903	1903	1903
88	1903	1903	1903
89	1903	1903	1903
90	1903	1903	1903
91	1903	1903	1903
92	1903	1903	1903
93	1903	1903	1903
94	1903	1903	1903
95	1903	1903	1903
96	1903	1903	1903
97	1903	1903	1903
98	1903	1903	1903
99	1903	1903	1903
100	1903	1903	1903

SECTION 2

PIN FUNCTION DESCRIPTION

W65C265S Interface Requirements

This section describes the interface requirements for the W65C265S single chip microcomputer. Figure 2-1 is the Interface Diagram for the W65C265S and Figure 2-2 shows the 84 Lead Chip Carrier pin out configuration.

		W65C816 Static CPU	Port 0	< 8 >	P0x/Axx
		576 X 8 RAM	Port 1	< 8 >	P1x/Axx
VDD (4) RESB	⇒ ⇐	8192 X 8 ROM	Port 2	< 8 >	P2x/Dx
WEB RUN/SYNC FCLKOB	⇐ ⇐ ⇐	Interrupt Registers & Logic	Port 3	< 8 >	P3x/Axx
FCLK BE/RDY CLK	⇒ ⇒ ⇒	Control Registers & Logic	Port 4	< 8 >	P4x/NMIB/ABORTB/IRQB/ PIB Control
CLKOB PHI2	⇐ ⇐	Clock Logic	Port 5	< 8 >	P5x/PE56/NE57/PIB data
VSS (4) BA/DODB	⇒ ⇐	8x16 bit Timers	Port 6	< 8 >	P6x/UARTx/TIN/TOUT/ PWM/PExx/NExx
		4 UART's	Port 7	8 >	P7x/CSxB
		PIB	2 Tone Generators	2 >	TGx

Figure 2-1 W65C265S Interface Diagram

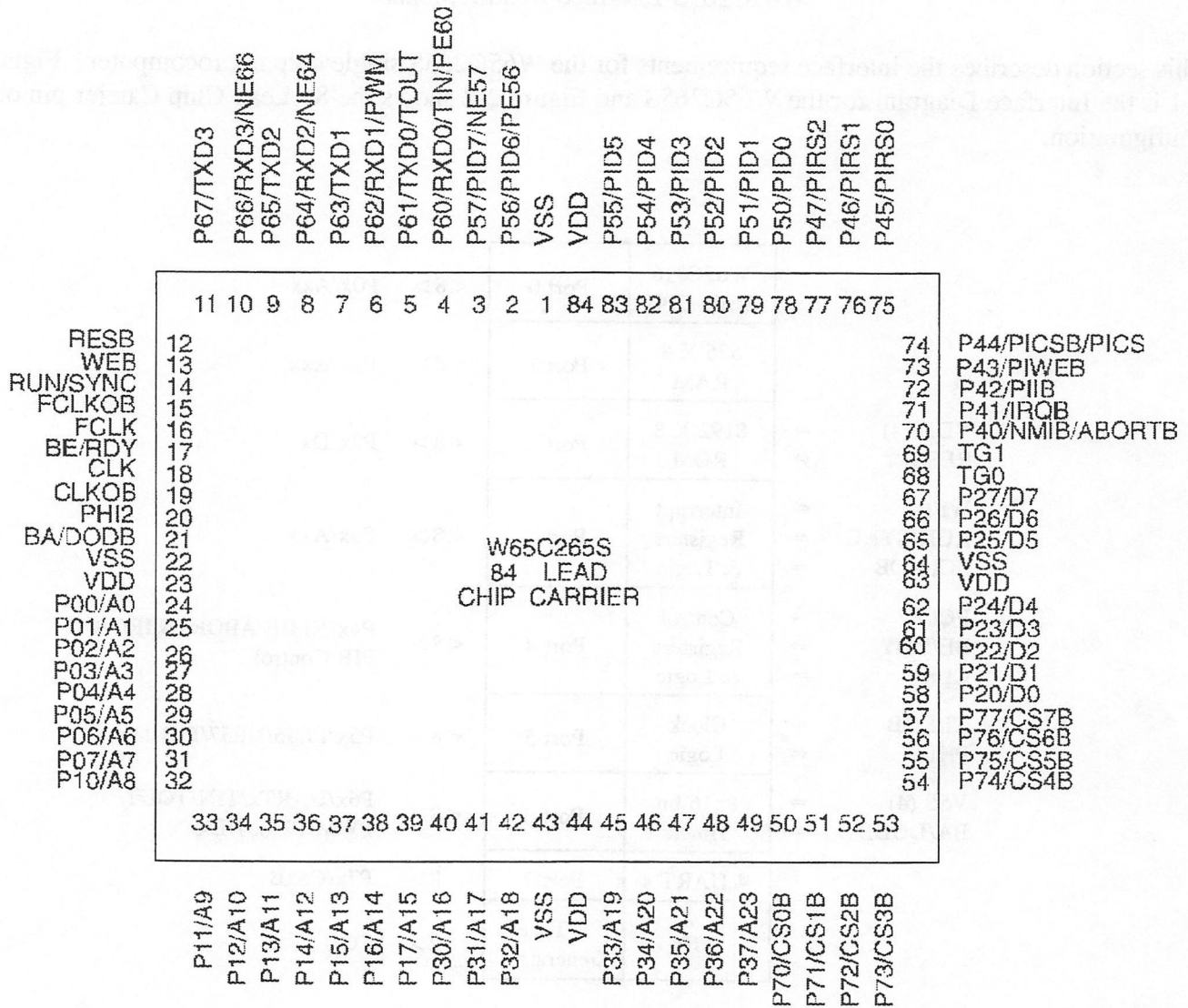

Figure 2-2 W65C265S 84 Lead Chip Carrier Pinout Designation

2.1 Write Enable (active low) (WEB)

The WEB signal is high when the microprocessor is reading data from external memory or I/O and high when it is reading or writing to internal memory or I/O. When WEB is low the microprocessor is writing to external memory or external I/O. The WEB signal is bidirectional; when BE/RDY is low this is an input for DMA operations to on-chip RAM or I/O. When BE/RDY is high the internal microprocessor controls WEB.

2.2 RUN and SYNC outputs with WAI and STP defined (RUN/SYNC)

- 2.2.1 The RUN function of the RUN/SYNC output is pulled low as the result of a WAI or STP instruction. RUN is used to signal an external oscillator to start PHI2. The processor is stopped when RUN is low.
- 2.2.2 When BCR3=1 (Toolbox emulation mode), the SYNC function (SYNC=1 indicates an opcode fetch) is multiplexed on RUN/SYNC during PHI2 low time and RUN is multiplexed during PHI2 high time. When BCR3=0 (normal operating mode), the RUN function is output during the entire clock cycle. An ICE system can demultiplex RUN/SYNC to provide full emulation capability for the RUN function.
- 2.2.3 The BE/RDY input has no effect on RUN/SYNC.
- 2.2.4 When RUN goes low the PHI2 signal may be stopped when high or low; however, it is recommended PHI2 stop in the high state. When RUN goes high due to an enabled interrupt or reset, the internal PHI2 clock is requested to start. The clock control function is referred to as the RUN function of RUN/SYNC.
- 2.2.5 The WAI instruction pulls RUN low during PHI2 high time. RUN stays low until an enabled interrupt is requested or until RESB goes from low to high, starting the microprocessor.
- 2.2.6 The STP instruction pulls RUN low during PHI2 high time and stops the internal PHI2 clock. RUN remains low and the clock remains stopped until RESB goes from low to high.
- 2.2.7 FCLK can be started or stopped by writing to System Speed Control Register (SSCR) bit 0. When SSCR0=0 (reset forces SSCR0=0), FCLK is stopped. When SSCR0=1, FCLK is started. When starting FCLK oscillator, the system software should wait (100 milliseconds or an appropriate amount of time) for the oscillator to be stable before using FCLK.

2.3 Phase 2 Clock Output (PHI2)

PHI2 output is the main system clock used by the microprocessor for instruction timing, general on-chip memory, and I/O timing. PHI2 also is used by the timers when enabled for counting PHI2 clock pulse. The PHI2 clock source is either CLK or FCLK depending on the value of System Speed Control Register bit 1 (SSCR1). When SSCR1=0, then CLK is the PHI2 clock source. When SSCR1=1, then FCLK is the PHI2 clock source.

2.4 Clock Inputs (CLKOB, FCLKOB Outputs) (CLK, FCLK)

CLK and FCLK inputs are used by the timers for PHI2 system clock generation, counting events or implementing Real Time clock type functions. CLK should always be equal to or less than one-fourth the FCLK clock rate when FCLK is running (see the timer description for more information). CLKOB, FCLKOB outputs are the inverted CLK and FCLK inputs that are used for oscillator circuits that employ crystals or a resistor-capacitor time base.

2.5 Bus Enable and RDY Input (BE/RDY)

- 2.5.1 BE/RDY controls the address bus, data bus and WEB signals. When RESB goes high signaling in the power-up condition, the processor starts; and if BE/RDY was low when RESB went from low to high then the Bus Control Register (BCR) bits 0, 3, and 7 (BCR0, BCR3, and BCR7) are set to 1 (emulation mode). See Figure 1-1.
- 2.5.2 After RESB goes high BE/RDY controls the direction of the address bus (A0-A7, A8-A15, A16-A23), data bus (D0-D7) and WEB.
- 2.5.3 When BE/RDY goes low during PHI2 low time, the address bus and WEB are inputs, providing for DMA (direct memory and I/O access) for emulation purposes. Data from D0-D7 is written to any register addressed by A0-A15 when WEB is low. Data is read from D0-D7 when WEB is high. The W65C816S is stopped when BE/RDY is low, during PHI2 high time.
- 2.5.4 When BE/RDY is high, the A0-A15, D0-D7 and WEB are controlled by the on-chip microprocessor.
- 2.5.5 When BE/RDY is pulled low during PHI2 high time, BE/RDY does not affect the direction of the address, data BUS and WEB signals. When BE/RDY is pulled low in PHI2 high time, the W65C816S is stopped so that the processor may be single stepped in emulation.

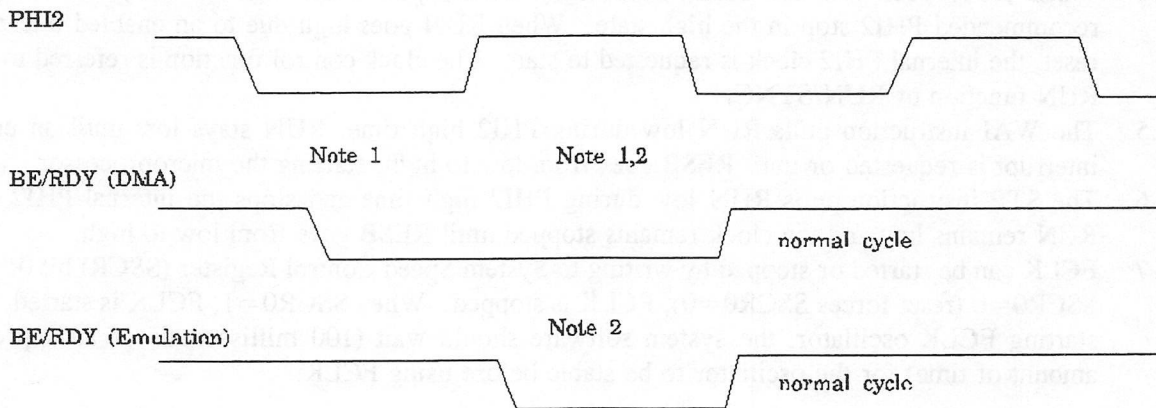

Figure 2-5 BE/RDY Timing Relative to PHI2

$$BE/RDY = BE \cdot (RDY + PHI2B)$$

Notes:

- 1) Address and WEB are inputs with data bus input except when reading on-chip I/O registers or memory. Use this mode for DMA.
- 2) W65C816S stopped with RDY function of BE/RDY pin. When BCR3=1, the W65C816S read or write of internal I/O register or memory is output on the external data bus so that the internal data bus may be traced in emulation.

2.6 Reset Input/Output (active low) (RESB)

- 2.6.1 When RESB is low for 2 or more processor PHI2 cycles all activity on the chip stops and the chip goes into the static low power state.
- 2.6.2 After a Reset, all I/O pins become inputs. Because of NOR gates on the inputs, RESB disables all input buffers. The inputs will not float due to the bus holding devices while RESB is low. Inputs that are unaffected by RESB are BE/RDY and WEB.
- 2.6.3 When RESB goes from low to high, RUN/SYNC goes high, the Bus Control Register is initialized to \$89 if BE/RDY is low or to \$00 if BE/RDY is high. The MPU then begins the power-up reset interrupt sequence in which the program counter is loaded with the reset vector that points to the first instruction to be executed. (See WDC's W65C816S microprocessor data sheet for more information and instruction timing.)
- 2.6.4 The reset sequence takes 9 cycles to complete before loading the first instruction opcode.
- 2.6.5 RESB is a bidirectional pin which is pulled low internally for "restarting" due to a "monitor time out", Timer M times out causing a system Reset. (See section 1.5, The Timers for more information.)

2.7 Positive Power Supply (VDD)

VDD is the positive power supply and has a range of 2.0V to 5.5V for use in a wide range of applications.

2.8 Internal Logic Ground (VSS)

VSS is the system logic ground. All voltages are referenced to this supply pin.

2.9 I/O Port Pins (Pxx)

- 2.9.1 All ports, except Port 7, which is an output Port, are bidirectional I/O ports. Each of these bidirectional Ports has a port data register (PDx) and port data direction register (PDDx). A zero ("0") in PDDxx defines the associated I/O pin as an input with the output transistors in the "off" high impedance state. A one ("1") in PDDxx defines the I/O pin as an output. A read of PDx always "reads" the pin. After reset, all Port pins become input pins with both the data and data direction registers reset to 0.
- 2.9.2 Port 7 has a Chip Select register (PCS) that is used to enable Chip Selects (CSxB). A "1" in bit x of PCSx enables Chip Select CSx- to be output over P7x while a "0" in PCSx specifies the value in the output data register is to be output on P7x. Port 7 data register is set to all "1's" after Reset, and PCS is cleared to all "0's" after Reset.

2.10 Address Bus (Axx)

Ports 0, 1, and 3 are also the address bus A0-A23 when configured by the Bus Control Register (BCR). When BCR0 and BCR7 are set to "1" and BCR3=0 (normal operating mode) for external memory addressing, Axx are all "1's" when addressing on-chip memory. When BCR3=1 (emulation mode), the address bus is always active so that an emulator can trace internal read and write operations.

2.11 Data Bus (Dx)

Port 2 is the data bus D0-D7 when configured by the Bus Control Register (BCR). (See section 1.4 for BCR mode selection.) When BCR0 and BCR7 are set to a "1" and BCR3=0 (normal operating mode) for external memory addressing, Dx are all "1's" when addressing on-chip memory. When BCR3=1 (emulation mode), the data bus is always active so that an emulator can trace internal read and write operations. During external memory cycles the data bus is in the Hi-Z state during PHI2 low time.

2.12 Positive Edge Interrupt inputs (PExx)

Port pin P56, P60 and P62 have Positive Edge sensitive interrupt inputs (PE56,PE60,PWM) multiplexed with the I/O. The associated bit is set (by an internal one-shot circuit) in the Interrupt Flag Register (IFRx) on a positive transition from "0" to "1". The transition from "1" to "0" has no effect on the IFR. When the associated Interrupt Enable Register bit (IERx) is set to a "1", the MPU will be interrupted provided the interrupt flag bit in the MPU status register P (I flag) is cleared to a "0". When the I flag is "1", interrupts are disabled.

2.13 Negative Edge Interrupt inputs (NExx)

Port pin P57, P62, P64 and P66 have Negative Edge sensitive interrupt inputs (NE57,PWM,NE64,NE66) multiplexed with the I/O. The associated bit is set (by an internal one-shot circuit) in the Interrupt Flag Register (IFRx) on a negative transition from "1" to "0". The transition from "0" to "1" has no effect on the IFR. When the associated Interrupt Enable Register bit (IERx) is set to a "1", the MPU will be interrupted provided the interrupt flag bit in the MPU status register P (I flag) is cleared to a "0". When the I flag is a "1", interrupts are disabled.

2.14 Chip Select outputs (active low) (CSxB)

The CSxB Chip Select outputs are enabled (individually) as outputs on Port 7 with the PCS register. Each of the eight chip selects is dedicated to one block of external memory defined by the programmable chip select registers; the mapping of each chip select to external addresses is given in Table 1-5, System Memory Map.

2.15 Level Sensitive Interrupt Request input (IRQB)

The I/O function of port pin P41 is multiplexed with IRQB Level Sensitive Interrupt input that is selected by Bus Control Register bit 6 (BCR6). When IRQB is held low the Edge Interrupt Flag Register Bit 7 (EIFR7) is set to a "1". When the Edge Interrupt Enable Register bit 7 (EIER7) is set to a "1" the MPU will be interrupted provided the I flag of the MPU is cleared to a "0" allowing interrupts. Unlike the edge interrupts, which do not hold the interrupt bit set, an interrupt will be generated as long as IRQB is low.

2.16 Non-Maskable Edge and ABORT Interrupt Input (NMIB/ABORTB)

The I/O Function of port pin P40 is multiplexed with both the NMIB edge triggered interrupt and the ABORT interrupt. When BCR6=1, the NMIB interrupt is enabled; the MPU will be interrupted on all negative edges of NMIB. Because the I flag cannot prevent NMIB from interrupting, NMIB is thought of as Non-Maskable. When BCR5=1, the ABORT interrupt is enabled. Should both BCR5 and BCR6 be set to "1", both NMIB and ABORT are enabled (normally, this is not desirable).

2.17 Asynchronous Receive Inputs/Transmitter Outputs (RXD_x, TXD_x)

The W65C265S has four full duplex Universal Asynchronous Receivers and Transmitters (UART_x) that may be enabled by the Asynchronous Control and Status Registers (ACSRs). When a Receiver is enabled by ACSR_{x0}=1 then port pin P60, P62, P64 or P66 becomes the Asynchronous Receiver Input (RXD_x). When a Transmitter is enabled by ACSR_{x4}=1, then port pin P61, P63, P65 or P67 becomes the Asynchronous Transmitter Output (TXD_x).

2.18 Timer 4 Input and Output (TIN, TOUT)

Timer 4 is controlled by TCR_x and TER_x. When the UART is not in use, Timer 4 can be used for counting input negative pulses on TIN. Timer 4 can also be used to put out a square wave or rectangular wave form on TOUT. When counting negative pulses on TIN the TIN frequency should always be less than one-half the frequency of PHI2. TOUT changes state on every time-out of Timer 4; therefore, varying waveform and frequency depends on the timer latch values and may be modified under software control. TIN is multiplexed on P60 and TOUT is multiplexed on P61.

2.19 Bus Available/Disable Output Data (BA/DODB)

The BA/DODB signal is low when the external address (A_{xx}) bus data (D_x) bus is required for operations. While BA/DODB is high, A_{xx} and D_x may be used for external memory operations such as DMA. BA/1 goes low after the address bus is valid for page mode RAS timing. If an internal cycle is processed then the external bus is available for DMA, etc. and BA stays high. This signal could be thought of as a valid memory address negative edge for sampling the address bus on the negative edge.

2.20 Tone Generator Outputs (TG_x)

The Twin Tone Generator outputs (TG_x) are synthesized 16 step cosine waveform outputs as described in Section 1.11 Twin Tone Generators.

2.21 Parallel Interface Bus (PIB)

- 2.21.1 The Parallel Interface Bus (PIB) pins are used to communicate between processors in a "star" network configuration or as a co-processor on a "host" processor bus such as an IBM PC or compatible or an Apple II or Mac II personal computer. This PIB may also be used as part of the file server system for large memory systems.
- 2.21.2 The Parallel Interface Write Enable (PIWEB) input pin is used with the Parallel Interface Chip Select (low active)/Parallel Interface Chip Select (high active) (PICSB/PICS) signal to transfer data to and from the Parallel Interface Register selected by the Parallel Interface Register select (PIRS_x) input pins. When PIWEB and PICSB are configured by the Parallel Interface Bus Enable Register bit 1 (PIBER1=0), then the PIB interface is compatible with WDC microprocessor WE- logical operation with the chip select PICSB input. The use of PIWEB and PICS are configured by PIBER1=1.
- 2.21.3 The PIB interrupt output to the "host" is generated on the Parallel Interface Interrupt (PII) pin. The "host" interrupt is suggested to be received on the IRQ level interrupt input pin of the "host" processor.

2.22 Pulse Width Measurement Input (PWM)

The Pulse Width Measurement (PWM) input will cause the Timer 7 (T7) counter contents to be transferred to the T7 output latches on the edge(s) selected by the Timer Control Register bits TCR2 and TCR3. The contents of the counter is transferred and an edge interrupt is generated resulting in the EIRF3 being set.

SECTION 3

TIMING, AC AND DC CHARACTERISTICS

3.1 Absolute Maximum Ratings: (Note 1)

Table 3-1 Absolute Maximum Ratings

Rating	Symbol	Value	Unit
Supply Voltage	VDD	-0.3 to +7.0	V
Input Voltage	VIN	-0.3 to VDD +0.3	V
Operating Temperature	TA	-55 to +125	°C
Storage Temperature	TS	-55 to +150	°C

This device contains input protection against damage due to high static voltages or electric fields; however, precautions should be taken to avoid application of voltages higher than the maximum rating.

Notes:

1. Exceeding these ratings may result in permanent damage. Functional operation under these conditions is not implied.

3.2 DC Characteristics

VDD = 2.0V to 5.5V (except where noted), VSS = 0V, TA = 0°C to +70°C (except where noted)

Table 3-2 DC Characteristics

	Symbol	Min	Max	Unit
Input High Threshold Voltage CLK, FCLK, RESB, all other inputs	Vih	.9XVDD 0.7XVDD	VDD+0.3 VDD+0.3	V V
Input Low Threshold Voltage CLK, FCLK, RESB, all other inputs	Vil	VSS-0.3 VSS-0.3	.1XVDD .3XVDD	V V
Input Leakage Current (Vin=VSS to VDD, VDD=5.5V) all inputs	Iin	-1	+1	uA
Output High Voltage Ioh=-100uA, VDD=2.8V all outputs	Voh	0.9XVDD	-	V
Output Low Voltage Iol=100uA, VDD=2.8 all outputs	Vol	-	.1XVDD	V
Supply Current (No Load and all on-chip circuits operating)	Icc	2.8V 5.5V -	3 6 -	mA/MHz mA/MHz
Supply Current (No Load) TA=25°C Reset Condition RESB, BE/RDY=VSS; CLK=32768Hz, VDD=5.5V FCLK=HI, PHI2=HI	Ires	-	5	uA
STP Condition CLK=HI, VDD=2.8V FCLK=HI, PHI2=HI	Istp	-	1	uA
Wait for Interrupt Condition CLK=32768Hz FCLK=HI, VDD=2.8V	Iwai	-	5	uA
Capacitance (sample tested) (Vin=0, Ta=25°C, f=1MHz) all pins except VSS, VDD	Cin	-	10	pF

3.3 AC Characteristics

Table 3-3 AC Characteristics

Timing Parameter	Definition
tISA	Address input setup from PHI2
tIHA	Address input hold from PHI2
tODA	Address output delay from PHI2
tOHA	Address output hold from PHI2
tISD	Data input setup from PHI2
tIHD	Data input hold from PHI2
tODD	Data output delay from PHI2
tOHD	Data output hold from PHI2
tISB	BE input setup from PHI2
tIHB	BE input hold from PHI2
tODSY	SYNC output delay from PHI2
tISRR	RDY/RESB input setup from PHI2
tIHRR	RDY/RESB input hold from PHI2
tODRN	RUN output delay from PHI2
tOHRN	RUN output hold from PHI2
tISP	Port input setup from PHI2
tIHP	Port input hold from PHI2
tODP	Port output delay from PHI2
tOHP	Port output hold from PHI2
tISI	Interrupt input setup from PHI2
tIHI	Interrupt input hold from PHI2
tISU	UART Data input setup from PHI2
tIHU	UART Data input hold from PHI2
tODU	UART Data output delay from PHI2
tOHU	UART Data output hold from PHI2
tODD (DMA)	Data output delay from PHI2 (ROM read)
tODPH	PHI2 output delay from CLK/FCLK
tODCSR	CS output delay from PHI2 rising
tODCSF	CS output delay from PHI2 falling
tR	FCLK/CLK risetime
tF	FCLK/CLK falltime
tBR	BE/RDY to RESB
tBV	BE/RDY to D0-7, A0-15, WEB Valid
CEXT	External Capacitive load
tCYC	CLK cycle time
tPWL	CLK low time
tPWH	CLK high time
tCYC2	PHI2 cycle time
tPWL2	PHI2 low time
tPWH2	PHI2 high time
tCYCF	FCLK cycle time
tPWLF	FCLK low time
tPWHF	FCLK high time

3.4 AC Parameters

Table 3-4 AC Parameters

Timing Parameter	VDD=1.8V 50 KHz		VDD=2.8V 1 MHz		VDD=5V +/-10% 2MHz		Units
	Min	Max	Min	Max	Min	Max	
tISA	3960	-	460	-	210	-	nS
tIHA	20	-	20	-	20	-	nS
tODA	-	2800	-	280	-	180	nS
tOHA	20	-	20	-	20	-	nS
tISD	2700	-	270	-	100	-	nS
tIHD	20	-	20	-	20	-	nS
tODD	-	3300	-	330	-	150	nS
tOHD	10	-	10	-	10	-	nS
tISB	3900	-	390	-	180	-	nS
tIHB	20	-	20	-	20	-	nS
tODSY	-	2700	-	270	-	150	nS
tISRR	700	-	70	-	40	-	nS
tIHRR	20	-	20	-	20	-	nS
tODRN	-	3300	-	330	-	150	nS
tOHRN	20	-	20	-	20	-	nS
tISP	2700	-	270	-	100	-	nS
tIHP	20	-	20	-	20	-	nS
tODP	-	2800	-	280	-	180	nS
tOHP	20	-	20	-	20	-	nS
tISI	800	-	80	-	40	-	nS
tIHI	20	-	20	-	20	-	nS
tISU	#1	-	80	-	40	-	nS
tIHU	#1	-	20	-	20	-	nS
tODU	#1	-	-	300	-	150	nS
tOHU	#1	-	10	-	10	-	nS
tODD (DMA)	-	3800	-	380	-	200	nS
tODPH	-	2000	-	200	-	100	nS
tODCSR	0	1000	0	100	0	00	nS
tODCSF	0	1000	0	100	0	50	nS
tR	-	100	-	100	-	50	nS
tF	-	100	-	100	-	100	nS
tBR	2000	-	200	-	100	100	nS
tBV	-	1900	-	190	-	-	nS
CEXT	50	-	50	-	50	90	nS
tCYC	16000	inf.	4000	inf.	2000	-	nS
tPWL	8000	inf.	2000	inf.	1000	inf.	nS
tPWH	8000	inf.	2000	inf.	1000	inf.	nS
tCYC2	TCYCF	inf.	TCYCF	inf.	TCYCF	inf.	nS
tPWL2	.5*TCYC2	inf.	.5*TCYC2	inf.	.5*TCYC2	inf.	nS
tPWH2	.5*TCYC2	inf.	.5*TCYC2	inf.	.5*TCYC2	inf.	nS
tCYCF	4000	inf.	1000	inf.	500	inf.	nS
tPWLF	2000	inf.	500	inf.	250	inf.	nS
tPWHF	2000	inf.	500	inf.	250	inf.	nS

3.5 AC Timing Diagram Notes

1. t_{CYC} must always be equal to or greater than four times t_{CYCF} when FCLK is running.
2. Rise and Fall Times for all signals are measured on a sample basis from $.3xV_{DD}$ to $.7xV_{DD}$.

The Rise and Fall times are not programmable on the automated test system that is used for production testing. A typical Rise and Fall time is 5-10ns; therefore, the spec indicates the duty cycle of the clock as tested ($t_{PWL} = t_{CYC}/2 - t_F$).

The Rise and Fall times of 100ns indicate output Rise and Fall times. The most critical Rise and Fall times are for PHI2 because all timing is related to PHI2.

The input Rise and Fall times can affect the input setup time (t_{IS}), output delay time (t_{OD}) and hold time (t_H). This must be taken into account in an application. At 2MHz and 4MHz the worst case input Rise and Fall times may prevent a system from working.

3. Hold Time for all inputs and outputs is relative to the associated clock edge.

3.6 AC Timing Diagrams

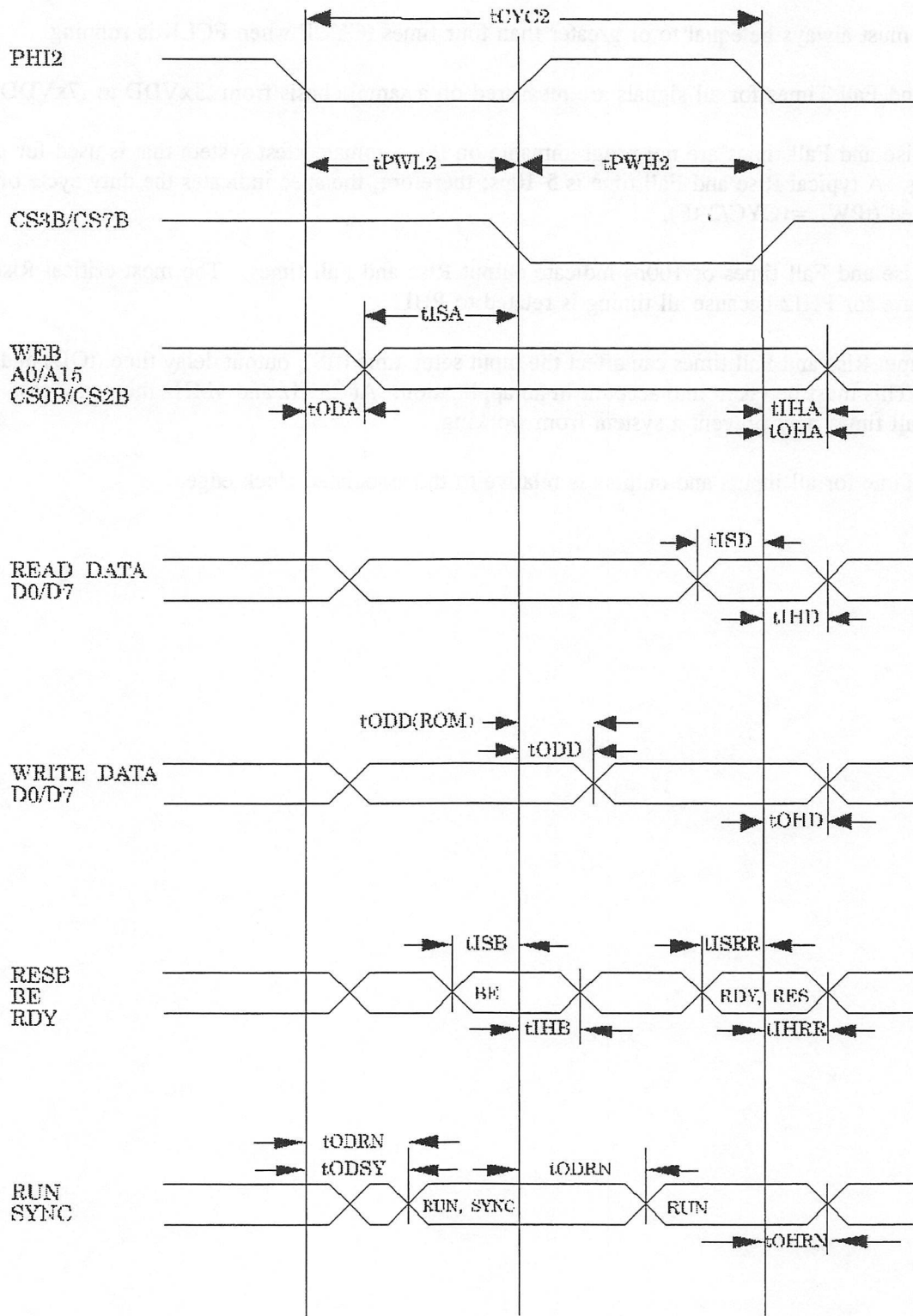
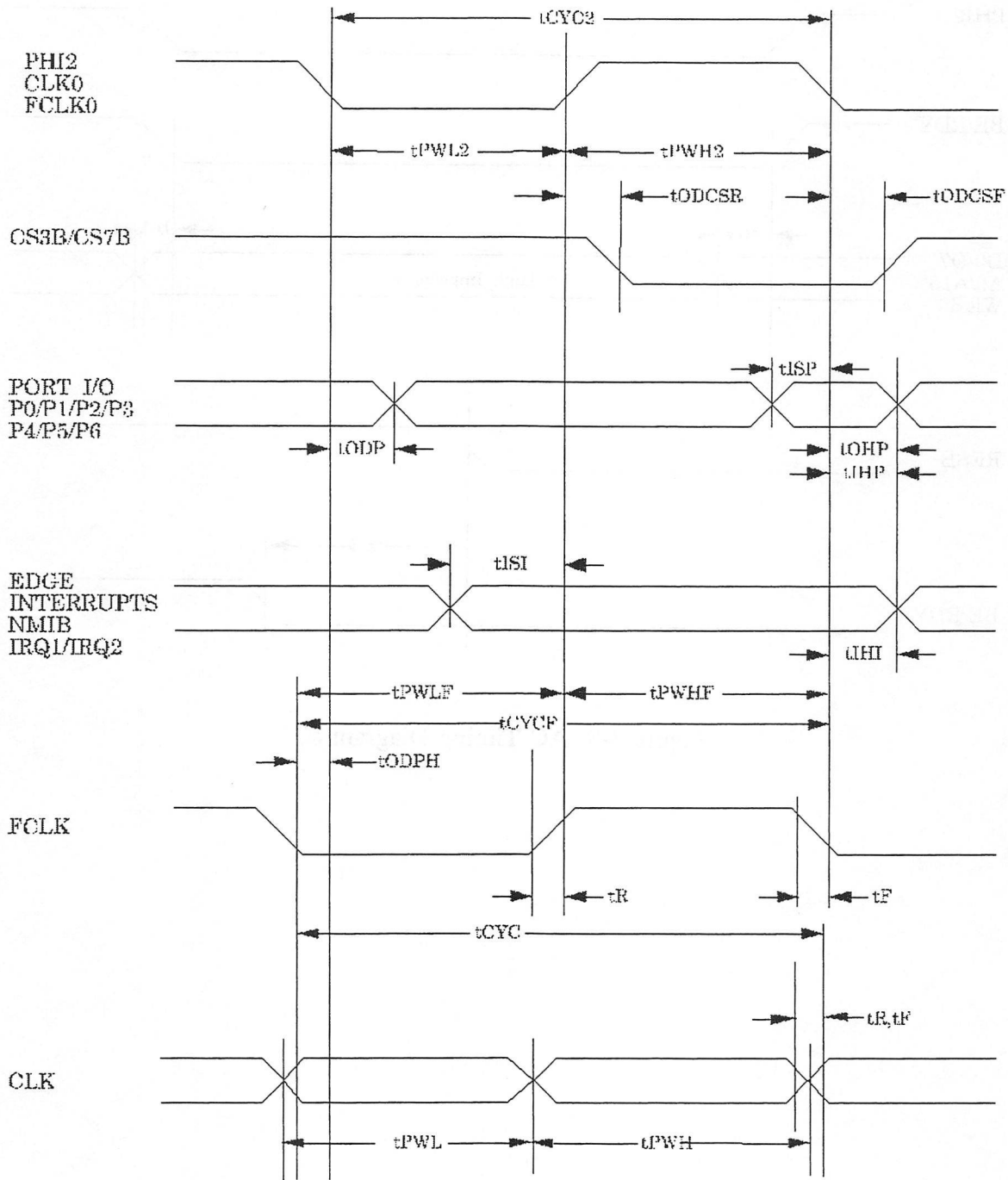

Figure 3-1 AC Timing Diagram #1



Notes:

1. Voltage levels shown are VL = VSS and VH = VDD.
2. Measurement points shown are .5xVDD and .5xVDD.
3. CLK can be asynchronous, tCYC equal or greater than 4xtCYCF.
4. Address and data hold time relative to PHI1 and/or CSx-is 20ns. The PHI2 and CSx- timing is controlled by TCR11. When TCR11=0 PHI12 and CSx- are related to CLK. When TCR11=1, PHI2 and CSx- are related to FCLK.

Figure 3-2 AC Timing Diagram #2

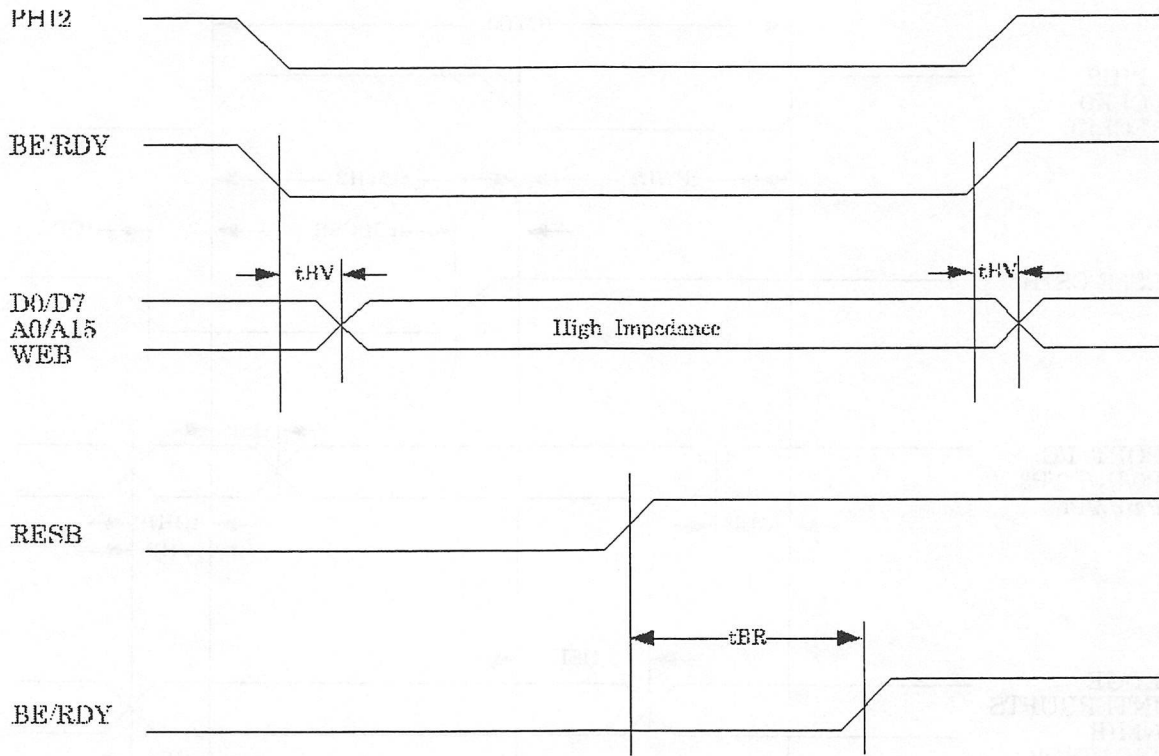

Figure 3-3 AC Timing Diagram #3

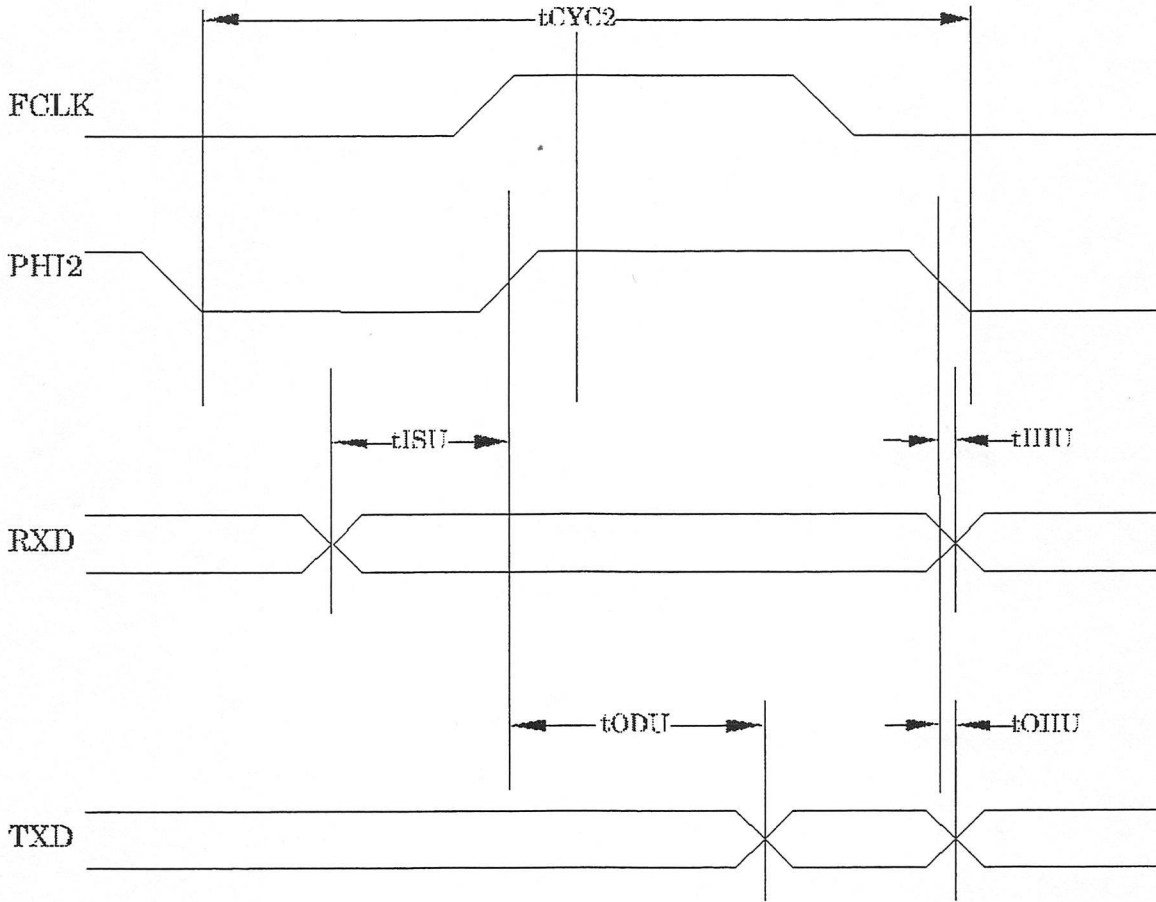
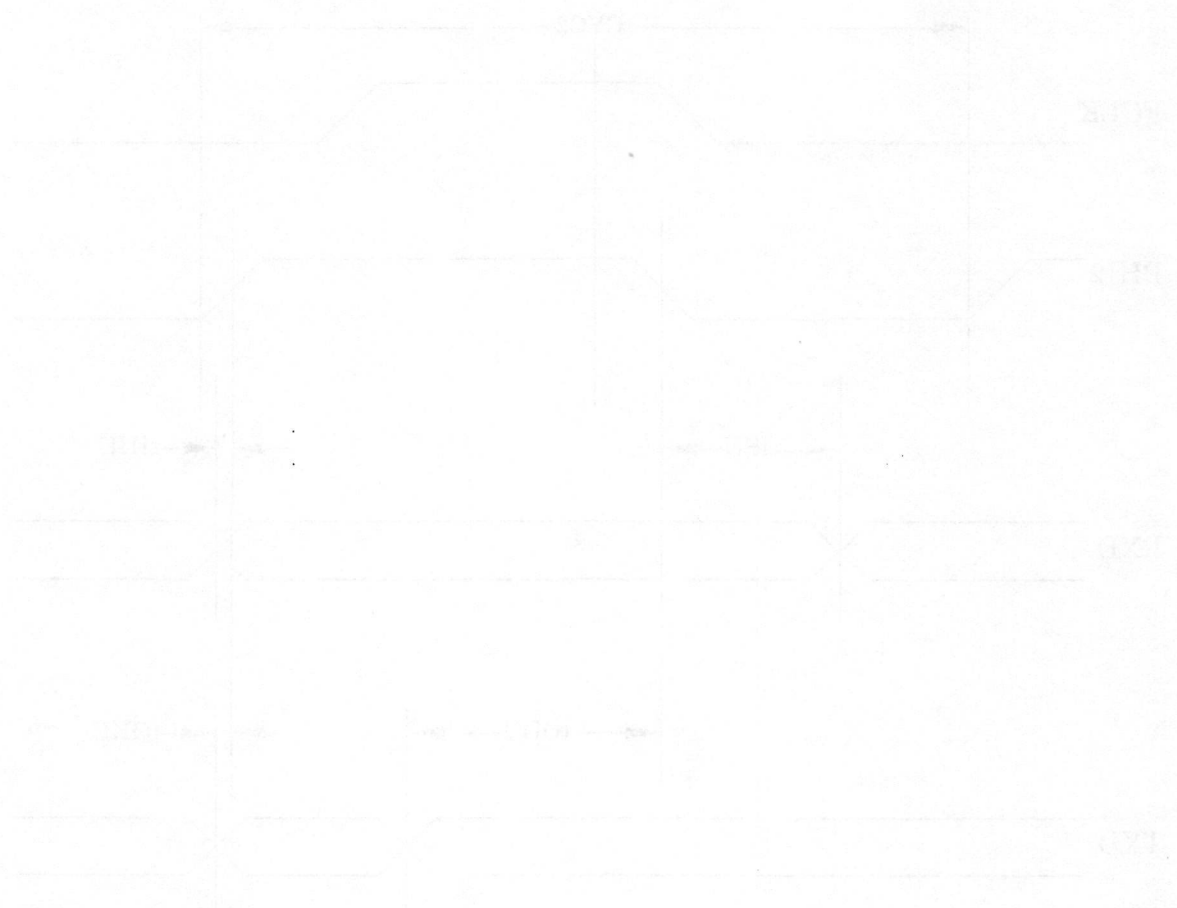

Figure 3-4 AC Timing Diagram #4



SECTION 05 20 00 - ROOFING

SECTION 4

ORDERING INFORMATION

W65C265SPL-4	
Description	W
W-Standard	
Product Identification Number	65C265S
Package	PL
P-plastic dual in-line, 84 leads	
PL-plastic leaded chip carrier, 84 leads	
Temperature/Processing	
Blank- 0°C to + 70°C	
Performance Designator	-4
Designators selected for speed and power. -2 2MHz -4 4MHz -6 6MHz -8 8MHz -10 10 MHz -3 3MHz -5 5MHz -7 7MHz -9 9MHz	

General sales or technical assistance, and information about devices supplied to a custom specification may be requested from:

The Western Design Center, Inc.
2166 East Brown Road
Mesa, Arizona 85213
Phone: 602-962-4545 Fax: 602-835-6442

WARNING:**MOS CIRCUITS ARE SUBJECT TO DAMAGE FROM STATIC DISCHARGE**

Internal static discharge circuits are provided to minimize part damage due to environmental static electrical charge build-ups. Industry established recommendations for handling MOS circuits include:

1. Ship and store product in conductive shipping tubes or conductive foam plastic. Never ship or store product in non-conductive plastic containers or non-conductive plastic foam material.
2. Handle MOS parts only at conductive work stations.
3. Ground all assembly and repair tools.

